

CNC ROTARY TABLE

RollerDrive CNC™

 **RCD, RT series**

For Machining Center from OKUMA

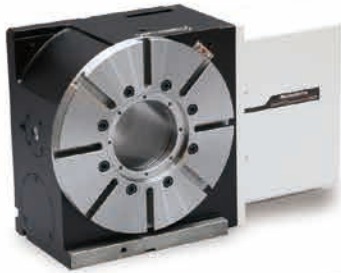

The Ultimate CNC Rotary Table



Zero-backlash Technology Delivers Unsurpassed Motion

The RollerDrive CNC is a rotary table designed to meet the requirements of machine tool manufacturers for greater speed and accuracy. The RollerDrive—Sankyo's zero-backlash reducer—delivers accurate output motion that stands up to external disturbances, unlike gearmotors or torque motors. It offers excellent rotary positioning accuracy of 10 seconds or less, and can hold up to heavy cutting forces on hard steel.

The heavy-duty RollerDrive CNC has no internal part wear and no loss of accuracy over long-term use, thus eliminating the need for regular calibration or adjustments.

Theory of Operation of the RollerDrive

The RollerDrive uses the roller gear mechanism, one of the finest motion control mechanisms available. The unit is constructed from an input shaft (the roller gear cam) and a turret (output shaft) fitted with roller followers. The roller followers are preloaded against a screw-like input shaft to completely eliminate backlash. Our proprietary adjustment mechanism provides optimum preload.

The roller followers planted in the turret use internal roller bearings to transfer torque while rotating. This ensures zero backlash, outstanding precision, and excellent efficiency without causing wear, while providing long-term consistent accuracy.

Exclusive zero-backlash construction

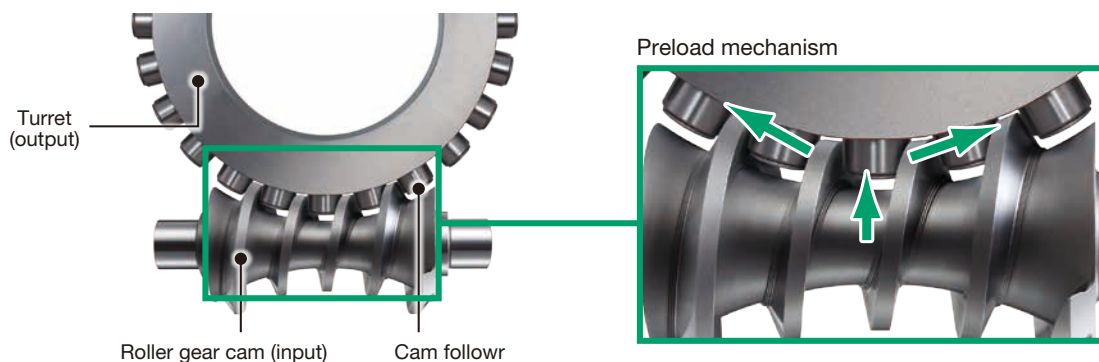

Features

➤➤ **Rolling contact**

➤➤ **Preload**

- ✓ No backlash (play).
- ✓ High accuracy and good efficiency.
- ✓ Preloadable for high rigidity.
- ✓ Clamless machining reduces positioning time.
- ✓ No deterioration of accuracy over time, initial accuracy is maintained for an extended period.

No Maintenance and Excellent Price Performance

Consistent long-term accuracy without maintenance.

► **Worm gear models**

Accuracy declines over time. Requires maintenance to achieve initial accuracy.

► **RollerDrive**

Accuracy is consistent with no maintenance even after 5 million operation cycles.

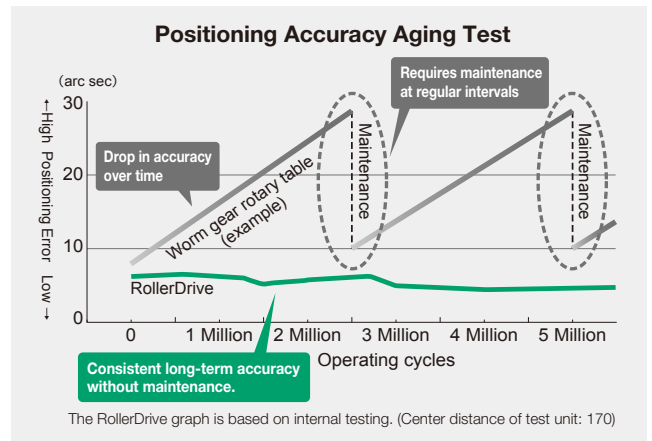

Cost Comparison with a Worm Gear Rotary Table

Offers Long-term Use without Maintenance

► **Worm gear models**

Maintenance costs occur once or twice a year to adjust the backlash.

► **RollerDrive**

Long-term use is possible without any mechanical maintenance. **Beats the cost of a worm gear even after adding annual running costs to the initial investment cost. Price performance continues thereafter.**

(Based on internal calculations.)

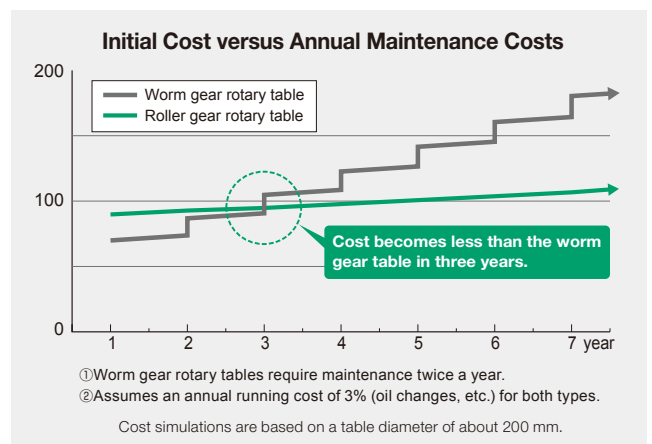

Shorter positioning time

Time comparison for 90° positioning

► **Conventional worm gear**

Clamping using hydraulic pressure or air pressure is required to suppress backlash.

► **RollerDrive**

Zero backlash and high rigidity eliminate the need for clamping. Compared to the worm gear type, positioning time is reduced to about one third.

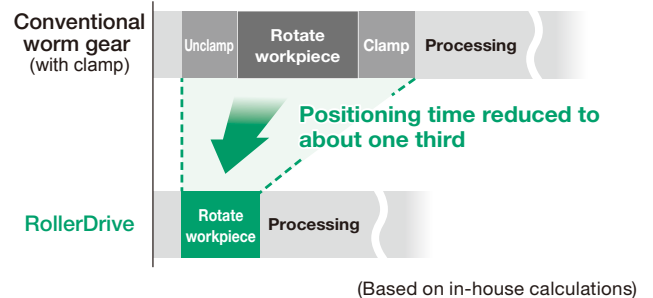

Extended Accuracy

Compared against a worm gear for over 5 million indexes.

► **Test conditions**

- Table size: Output table diameter: 170 mm
- Load inertia: 0.5 kgm²
- Index angle: 36° (unidirectional)
- Indexing time: 0.35sec

► **Results after 5 million indexes:**

Item	Worm gear	RollerDrive
Variation in positioning accuracy	24.2sec	0.9sec
Backlash (measured at R60)	18 μm (15 μm → 33 μm)	-

(Based on internal testing data.)

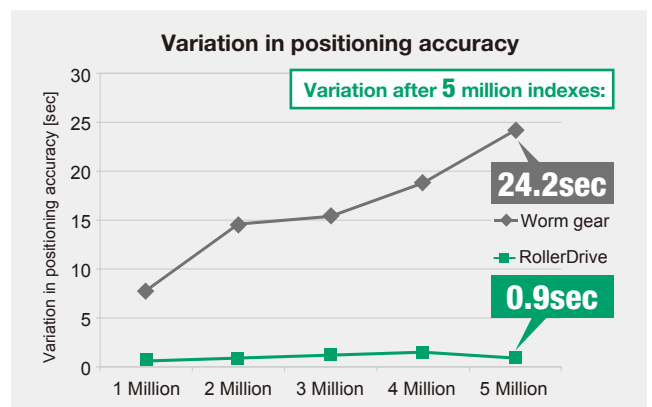

Sizing and Product Code

CNC Rotary Table Selection Chart

CNC Rotary Table		ACE CENTER		GENOS		MILLAC	
		MB-46VA/B	MB-56VA/VB	M460-VE	M560-V	468V II	561V II
1-axis	RCD170	○		○			
	RCD200	○		○			
	RCD250		○		○	○	○
	RCD300		○		○	○	○
2-axis	RT100					○	○



Product Code [1-axis Series]

Rotary table

1	2	3	4	5	6	
RCD170	A	R	B	R	1	
1	2		3		4	
Model	Servo motor		Motor mounting side		Connector position	
	Without brake				Connector type	
RCD170	A1	FANUC	R	Right	B	Rear
RCD200	E1	OKUMA	L	Left	S	Side
RCD250						
RCD300						

7	8	9
Options		Standard / Custom
Air / Hydraulic clamping		Blank
C	With clamp	Standard
Blank	None	X
Rotary joint ¹		Custom
J	Internal type	
H	External type	
Blank	None	

*1 There is no hollow bore in the table when the rotary joint is installed.

Motor mounting side	Connector position	Connector type / shape	Table shape															
R	B	R	<table border="1"> <thead> <tr> <th></th> <th>A</th> <th>B</th> </tr> </thead> <tbody> <tr> <td>RCD170</td> <td>(8)M8x1.25, 14DP</td> <td>140</td> </tr> <tr> <td>RCD200</td> <td>(8)M8x1.25, 14DP</td> <td>170</td> </tr> <tr> <td>RCD250</td> <td>(8)M10x1.5, 18DP</td> <td>210</td> </tr> <tr> <td>RCD300</td> <td>(8)M10x1.5, 18DP</td> <td>250</td> </tr> </tbody> </table>		A	B	RCD170	(8)M8x1.25, 14DP	140	RCD200	(8)M8x1.25, 14DP	170	RCD250	(8)M10x1.5, 18DP	210	RCD300	(8)M10x1.5, 18DP	250
	A	B																
RCD170	(8)M8x1.25, 14DP	140																
RCD200	(8)M8x1.25, 14DP	170																
RCD250	(8)M10x1.5, 18DP	210																
RCD300	(8)M10x1.5, 18DP	250																
L	S																	

Support table

1	2	3	4	
ST170A	C	J	X	
1	2		3	
Model	Options		Standard / Custom	
	Air / Hydraulic clamping		Rotary joint	
ST170A	C	With clamp	J	Internal type
ST250A	Blank	None	H	External type
			Blank	None
			Blank	Standard
			X	Custom

Tail stock

1	2	3	4	
TSS135	M	R	X	
1	2		3	
Model	Type		Handle side	
	M	Manual	R	Right
TSS135			L	Left
TSS185				
			Blank	Standard
			X	Custom

Product Code [2-axis Series]

Rotary table



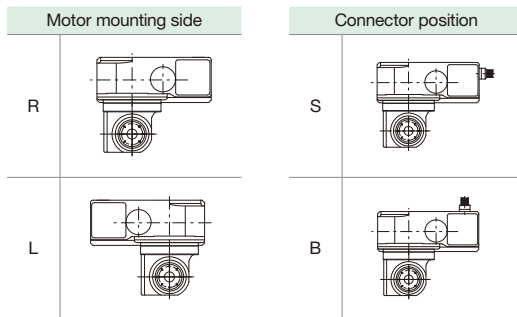

1	RT100	-	2	A	3	R	4	S
1			2	3		4		
Model		Servo motor	Motor mounting side		Connector position			
RT100		A	FANUC	R	Right	S	Side	
				L	Left	B	Rear	

5	J
5	
Options	
Rotary joint (Internal type) ^{*1}	
J	Internal type
Blank	None

*1 Use the rotary joint for the air supply. It is not suitable for supplying hydraulic oil.



Specifications [1-axis Series]

Specifications		RCD170	RCD200	RCD250	RCD300	
Table diameter	mm	Φ170	Φ200	Φ250	Φ300	
Table pilot bore diameter	mm	Φ60 ^{+0.03} ₀	Φ60 ^{+0.03} ₀	Φ110 ^{+0.035} ₀	Φ110 ^{+0.035} ₀	
Center height	mm	135	135	185	185	
Table T slot width	mm	12 ^{+0.018} ₀	12 ^{+0.018} ₀	12 ^{+0.018} ₀	12 ^{+0.018} ₀	
Keyway width	mm	18 ⁰ _{0.011}	18 ⁰ _{0.011}	18 ⁰ _{0.011}	18 ⁰ _{0.011}	
Clamp type (air 0.5 MPa, hydraulic 3.5 MPa)		Air / Hydraulic	Air / Hydraulic	Hydraulic	Hydraulic	
Clamp torque ^{*1}	N·m	310	310	1100	1100	
Motor shaft equivalent inertia ^{*2,3,7}	×10 ⁻⁴ kg·m ²	3.15	3.15	5.70 [5.70]	5.70 [5.70]	
Motor model (OKUMA)		BL-MT40M-40SN/M	BL-MT40M-40SN/M	BL-MT40M-40SN/M	BL-MT200M-40SN/M	
Motor model (FANUC)		-	-	αiS8/4000-B (A06B-2235-B100)	αiS8/4000-B (A06B-2235-B100)	
Minimum setting unit	deg	0.0001	0.0001	0.0001	0.0001	
Maximum table speed	min ⁻¹	70	70	60	60	
Gear ratio		1/50	1/50	1/60	1/60	
Indexing accuracy	arc.sec	±15	±15	±10	±10	
Repeatability	arc.sec	8	8	4	4	
Net weight	kg	57	59	110	115	
Allowable payload	Upright position ^{*4} 	kg	70 (140)	70 (140)	255 (510)	255 (510)
	Horizontal position 	kg	140	140	510	510
Allowable load	F 	N	21000	21000	52000	52000
	F×L with clamping 	N·m	310	310	1100	1100
	Continuous holding torque ^{*2,5,7}	N·m	236 [236]	236 [416]	296 [512]	296 [512]
	Maximum output torque ^{*2,4,6,7}	N·m	434 [362]	434 [544]	534 [987]	534 [987]
	F×L 	N·m	1300	1300	5500	5500
Allowable workpiece inertia	kg·m ²	1.1	1.1	8.3	8.3	
External rotary joint (number of ports)		6+1	6+1	10+1	10+1	
Internal rotary joint (number of ports)		6	6	8	8	

*1 Values for RCD170 and RCD200 are clamping torques when using an air hydro booster with a air pressure of 0.5 MPa as the supply source.

*2 Values for motor shaft equivalent inertia, and continuous / maximum holding torque are given for Okuma motors. Please contact Sankyo if a different motor is to be used.

*3 Motor shaft equivalent inertia does not include the inertia of the motor shaft.

*4 The allowable payload value for upright mounting shown in brackets applies when a tail stock or support table is used.

*5 The continuous / maximum holding torque is the allowable load torque when a clamp is not used.

*6 Maximum holding torque should not exceed 10 seconds with 20% duty.

*7 Value for [] is the value when using a Fanuc motor.

Dimensions [1-axis Series]

The drawings apply to the following specifications: R side motor mounting, rear connector.

Spring and Product Code

Specifications / Dimensions

Mount clamps(Accessories) / Precision Ratings

Main unit options

Auxiliary equipment

Layout dimensions on machine

Precautions

► RCD170

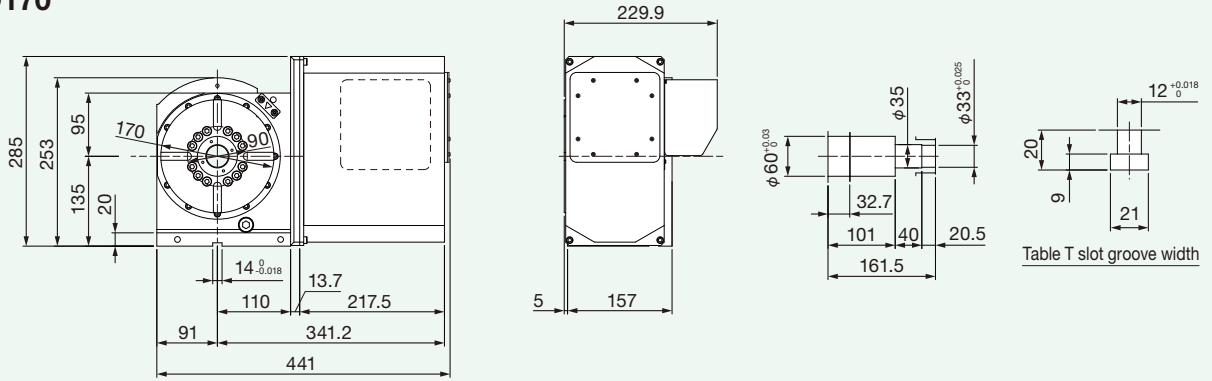

► RCD200

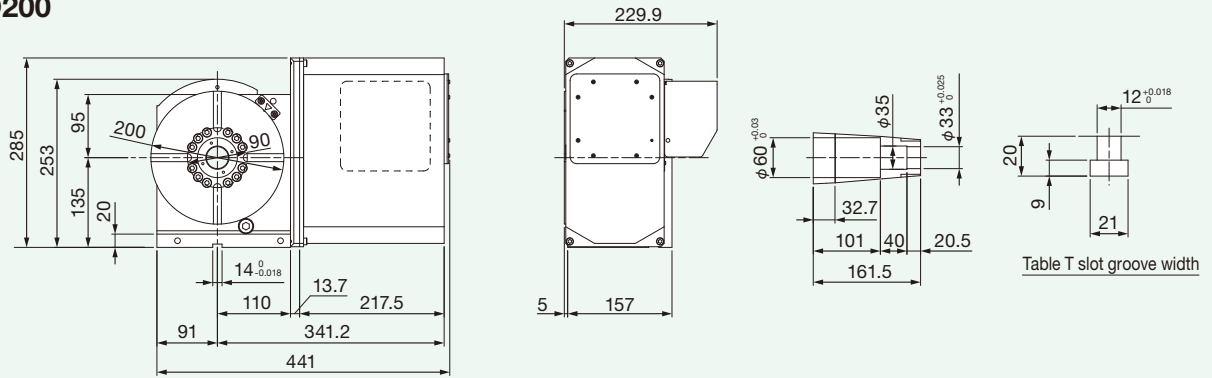



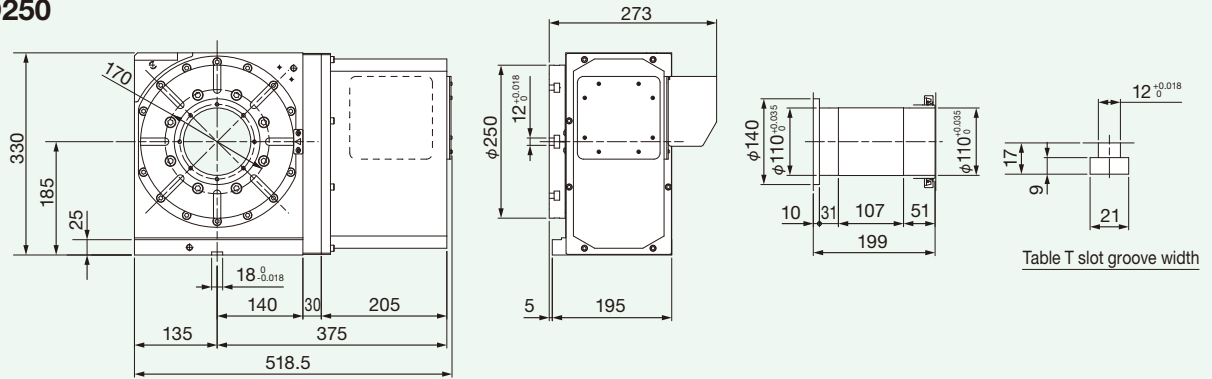

► RCD250

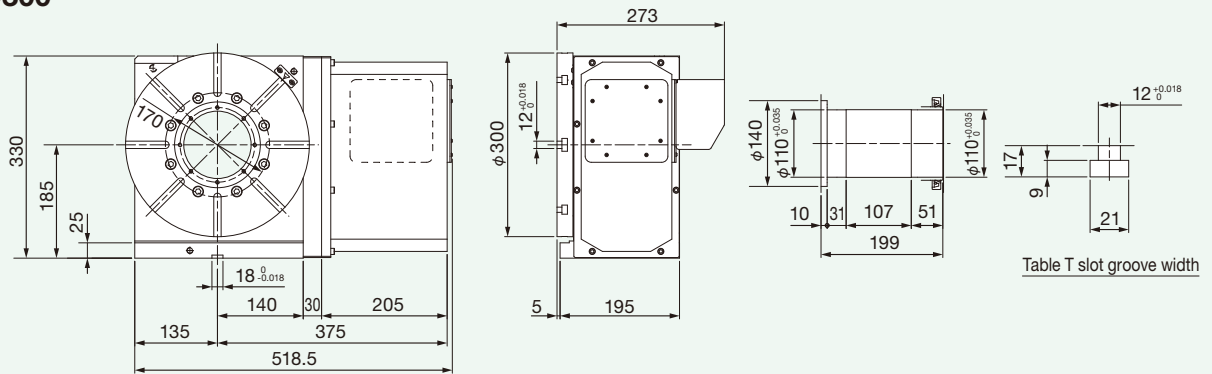

► RCD300

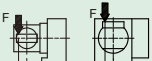
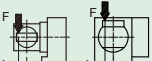

Specifications [2-axis Series]

Specifications		RT100		
		Rotary axis	Tilt axis	
Tilting angle	deg	-20 ~ +120		
Table diameter	mm	Φ100		
Table pilot bore diameter	mm	Φ40 ^{+0.025} ₀		
Center height (90 degrees)	mm	132		
Table surface height (0 degree)	mm	197		
Keyway width	mm	18 ⁰ _{-0.011}		
Motor shaft equivalent inertia ¹	×10 ⁻⁴ kg·m ²	0.92	1.98	
Motor model (FANUC)		αiS2/5000-B (A06B-2212-B000)	αiS4/5000-B (A06B-2215-B000)	
Minimum setting unit	deg	0.0001	0.0001	
Maximum table speed	min ⁻¹	100	55	
Gear ratio		1/48	1/90	
Indexing accuracy	arc.sec	±15	±10	
Repeatability	arc.sec	8	4	
Net weight	kg	91		
Allowable payload	0 degree 	kg	30	
	90 degrees 	kg	30	
Allowable load	F 	N	6016	
	F×L Continuous holding torque 	N·m	118	384
	F×L Maximum output torque ² 	N·m	213	611
	F×L 	N·m	290	
Allowable workpiece inertia	kg·m ²	0.1		
Internal rotary joint (number of ports) ³		2	-	

¹ Motor shaft equivalent inertia does not include the inertia of the motor shaft.

² Maximum holding torque should not exceed 10 seconds with 20% duty.

³ Use the rotary joint for the air supply. It is not suitable for supplying hydraulic oil.

Dimensions [2-axis Series]

The drawings apply to the following specifications: R side motor mounting, side connector.

► RT100

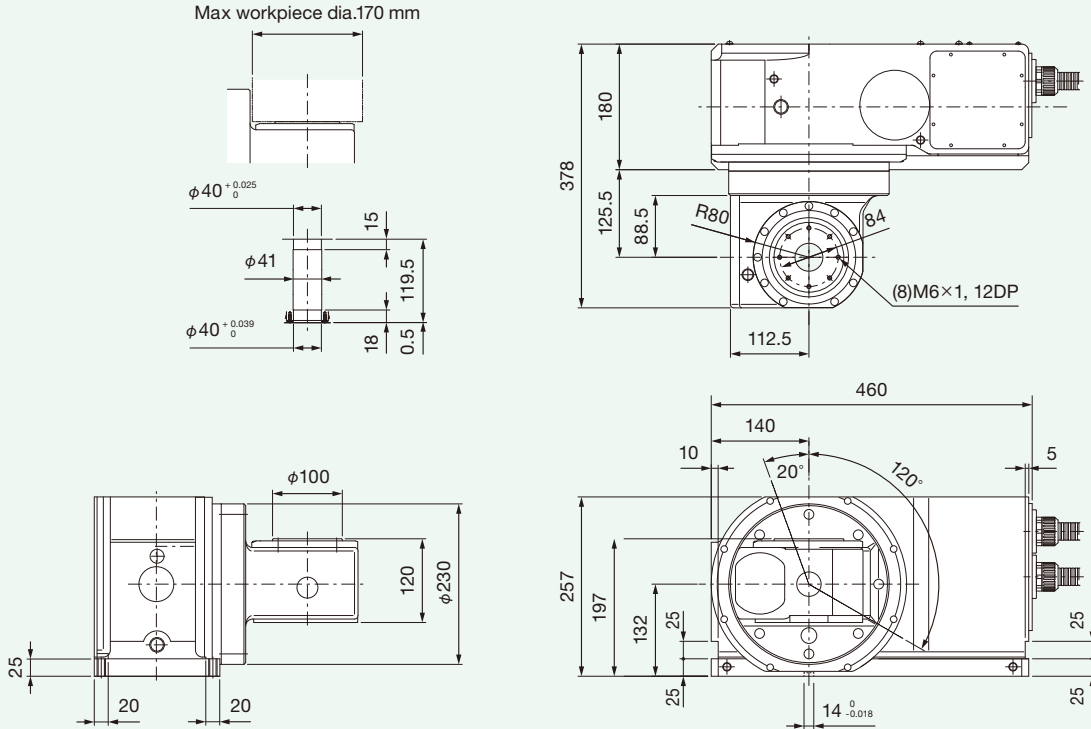

Workpiece interference region for tilting

	Tilting angle		
	-20° ~ 45°	-20° ~ 90°	-20° ~ 120°
RT100			

Spring and Product Code

Specifications / Dimensions

Mount clamps(Accessories) / Precision Ratings

Main unit options

Auxiliary equipment

Layout dimensions on machine

Precautions

Mount clamps (Accessories)

Model	Size	Mount clamps type / Qty. used
RCD	170	g, h (1 pc. each)
	200	g, h (1 pc. each)
	250	i (4 pcs.)
	300	i (4 pcs.)
RT	100	b (4 pcs.)

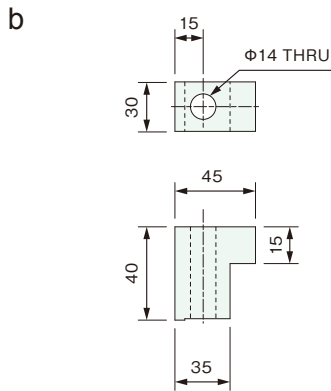
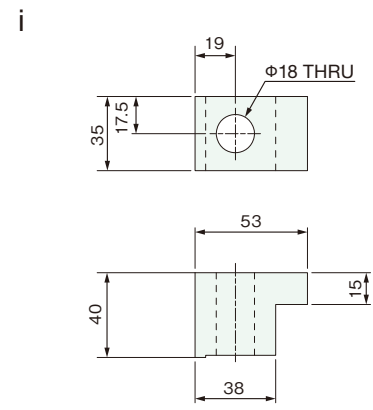
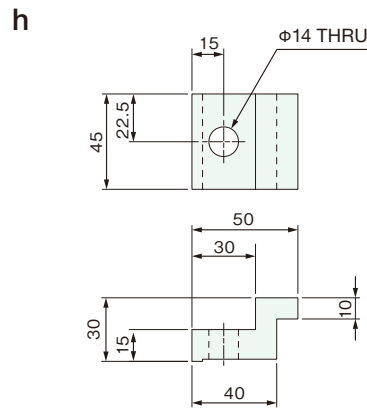
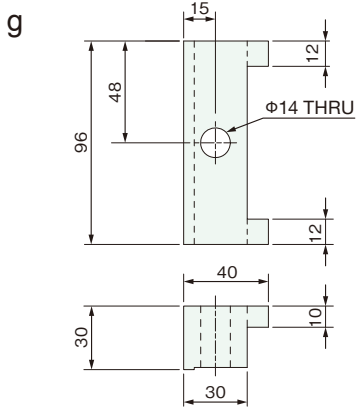

Precision Ratings

1-axis Series

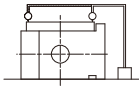
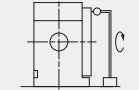
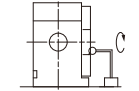
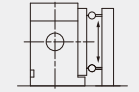
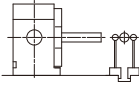
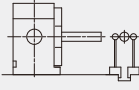
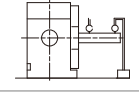
NO.	Measurement	Method	RCD170	RCD200	RCD250	RCD300
1	Parallelism between table top and reference surface for upright mounting		0.015mm	0.015mm	0.02mm	0.02mm
2	Runout of table top		0.01mm	0.01mm	0.01mm	0.01mm
3	Runout of table reference bore		0.01mm	0.01mm	0.01mm	0.01mm
4	Perpendicularity between table top and reference surface for upright mounting		0.02mm (must not lean forward)	0.02mm (must not lean forward)	0.02mm (must not lean forward)	0.02mm (must not lean forward)
5	Parallelism between rotary axis and guide blocks for reference surface for upright mounting		0.02mm/150mm	0.02mm/150mm	0.02mm/150mm	0.02mm/150mm
6	Deviation between rotary axis and guide blocks for reference surface for upright mounting		0.02mm	0.02mm	0.02mm	0.02mm
7	Parallelism between rotating center and reference surface for upright mounting		0.02mm/150mm	0.02mm/150mm	0.02mm/150mm	0.02mm/150mm
8	Indexing accuracy		±15arc.sec	±15arc.sec	±10arc.sec	±10arc.sec
9	Repeatability		8arc.sec	8arc.sec	4arc.sec	4arc.sec

2-axis Series

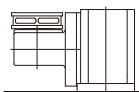
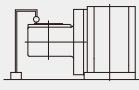
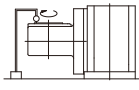
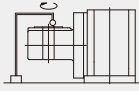
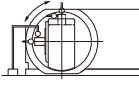
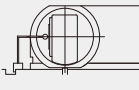
NO.	Measurement	Method	RT100
1	Straightness of table top		0.01mm over full length
2	Parallelism between table top and bottom surface of base		0.01mm
3	Runout of table top		0.01mm
4	Runout of table reference bore		0.01mm
5	Parallelism between tilt axis center line and bottom surface of base		0.02mm over full length
6	Parallelism between table top and guide block		0.02mm
7	Indexing accuracy	Rotary axis	±15arc.sec
		Tilt axis	±10arc.sec
8	Repeatability	Rotary axis	8arc.sec
		Tilt axis	4arc.sec

String and Product Code

Specifications / Dimensions

Mount clamps(Accessories) / Precision Ratings

Main unit options

Auxiliary equipment

Layout dimensions on machine

Precautions

Main unit options — Rotary joint

Specifications

Model	Size	Max. number of ports		Maximum actuation pressure
		Internal type	External type	
RCD	170	6	6+1 ^{*1}	Fluid: Air 0.7 MPa / Hydraulic 6 MPa
	200	6	6+1 ^{*1}	
	250	8	10+1 ^{*1}	
	300	8	10+1 ^{*1}	
RT	100	2	-	Fluid: Air 0.7 MPa ^{*4}

*1 The +1 indicates the port in the center bore.

*2 Make sure to furnish a line filter in the air supply line.

*3 Under prolonged use a small amount of actuation oil may leak from the oil port toward the adjacent air port. If possible, the adjacent ports should be left open for use as drain ports.

*4 Use the rotary joint for the air supply. It is not suitable for supplying hydraulic oil.

Internal type

► RCD170,200

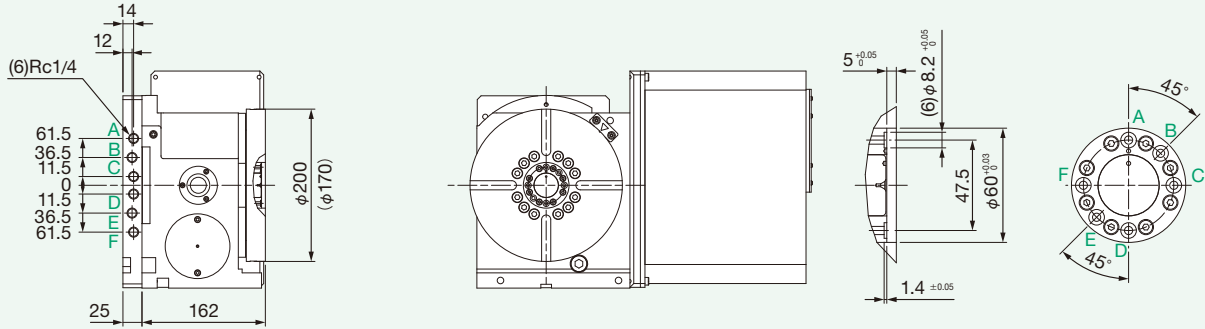

► RCD250,300

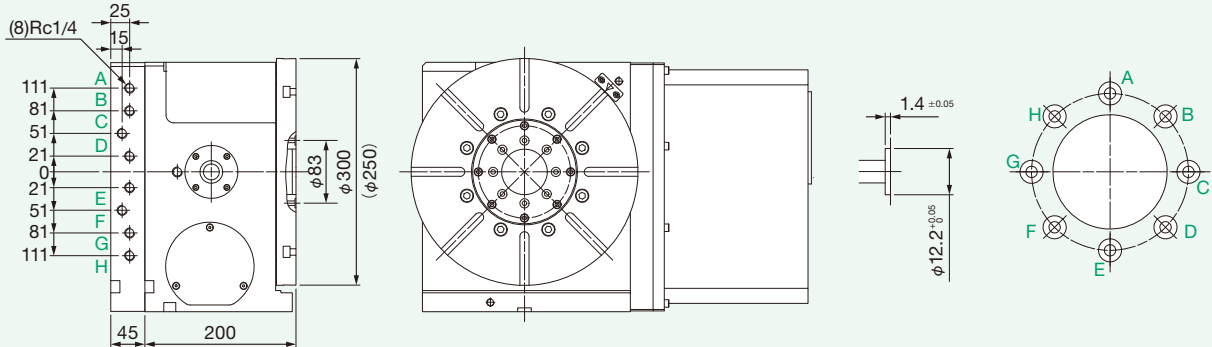

► RT100

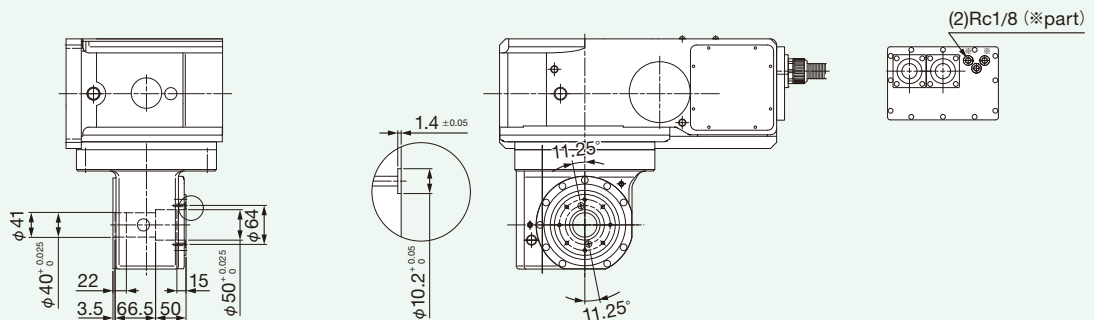

External type

► RCD170,200

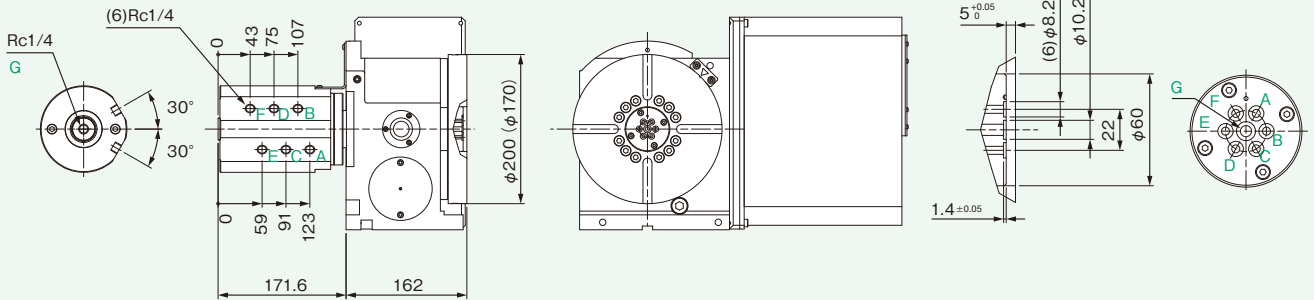

► RCD250,300

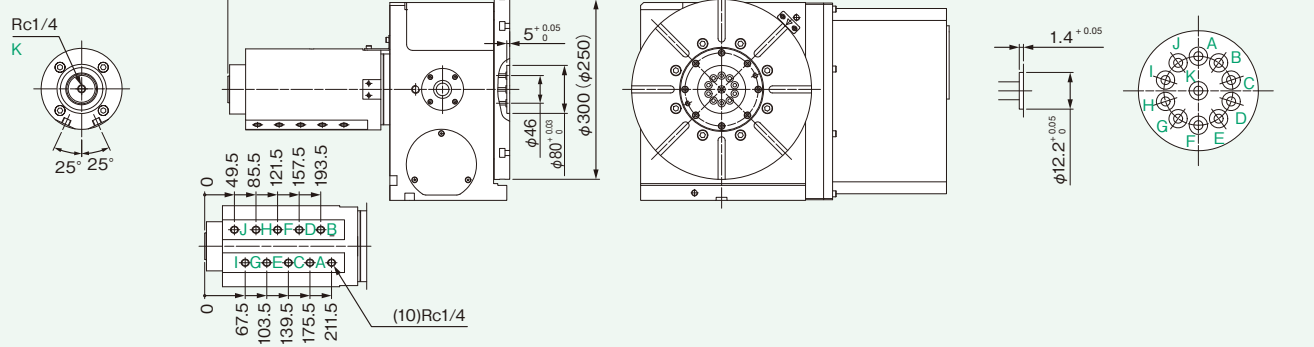

Spring and Product Code

Specifications / Dimensions

Mount clamps(Accessories) / Precision Ratings

Main unit options

Auxiliary equipment

Layout dimensions on machine

Precautions

Auxiliary equipment — Support table

Specifications

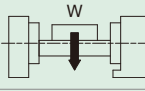
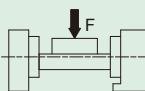
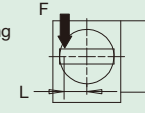
Specifications		ST170A		ST250A	
		RCD170	RCD200	RCD250	RCD300
Rotary table model		RCD170	RCD200	RCD250	RCD300
Table diameter	mm	Φ170		Φ250	
Table pilot bore diameter	mm	Φ60 ^{+0.03} ₀		Φ110 ^{+0.035} ₀	
Center height	mm	135		185	
Table T slot width	mm	12 ^{+0.018} ₀		12 ^{+0.018} ₀	
Keyway width	mm	18 ⁰ _{-0.011}		18 ⁰ _{-0.011}	
Clamp type (air 0.5 MPa, hydraulic 3.5 MPa)		Air / Hydraulic		Hydraulic	
Clamp torque ^{*1}		310		1200	
Inertia of rotating output part		2.10		20.00	
Maximum table speed		70		60	
Net weight		24		54	
Allowable payload ^{*2}	 kg	140		510	
Allowable load ^{*2}	F  N	18900		46300	
	F×L with clamping  N·m	620		2400	
	Continuous holding torque ^{*3,5}	N·m	236 [236]	236 [416]	296 [512]
	Maximum holding torque ^{*3,4,5}	N·m	434 [362]	434 [544]	534 [987]
External rotary joint (number of ports)		6+1		10+1	
Internal rotary joint (number of ports)		4		6	

*1 Values for ST170A is clamping torques when using an air hydro booster with an air pressure of 0.5 MPa as the supply source.

*2 The allowable payload and allowable load values apply to the entire set including the rotary table.

*3 The continuous / maximum holding torque is the allowable load torque when a clamp is not used.

*4 Maximum holding torque should not exceed 10 seconds with 20% duty.

*5 Value for [] is the value when using a Fanuc motor.



Auxiliary equipment — Support table dimensions

► ST170A

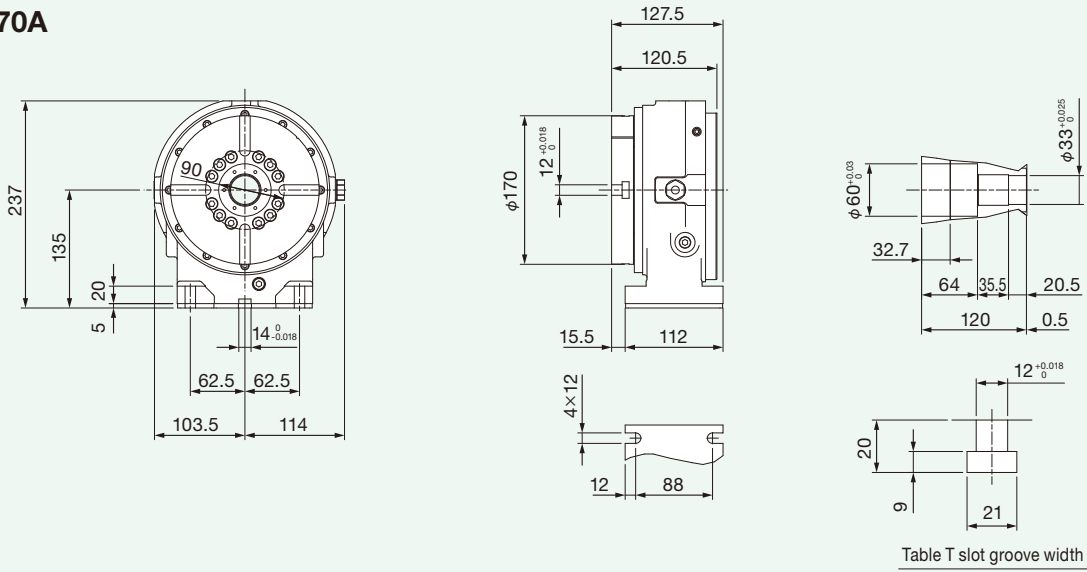

► ST250A

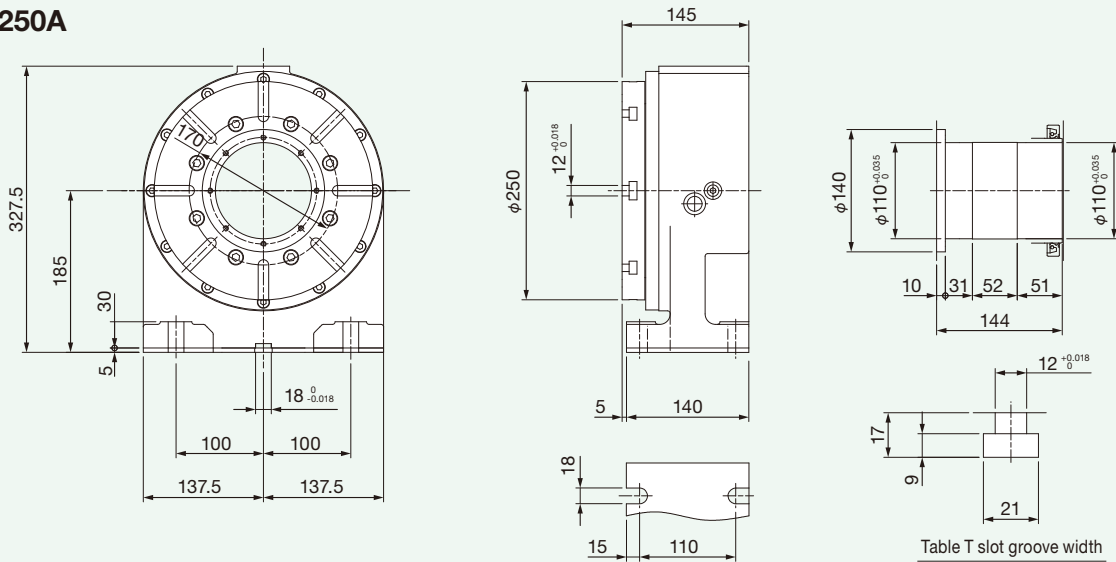

String and Product Code

Specifications / Dimensions

Mount clamps (Accessories) / Precision Ratings

Main unit options

Auxiliary equipment

Layout dimensions on machine

Precautions

Support table options — Rotary joint

Specifications

Model	Size	Max. number of ports		Maximum actuation pressure
		Internal type	External type	
ST	170A	4	6+1 ^{*1}	Fluid: Air 0.7 MPa / Hydraulic 6 MPa
	250A	6	10+1 ^{*1}	

- *1 The "+1" indicates a port using the center bore.
- *2 Be sure to use a line filter in the air supply.
- *3 During prolonged use, a small amount of actuation oil may leak from an oil port to an adjacent air port. If possible, the adjacent port should be left open as a drain port.

Internal type

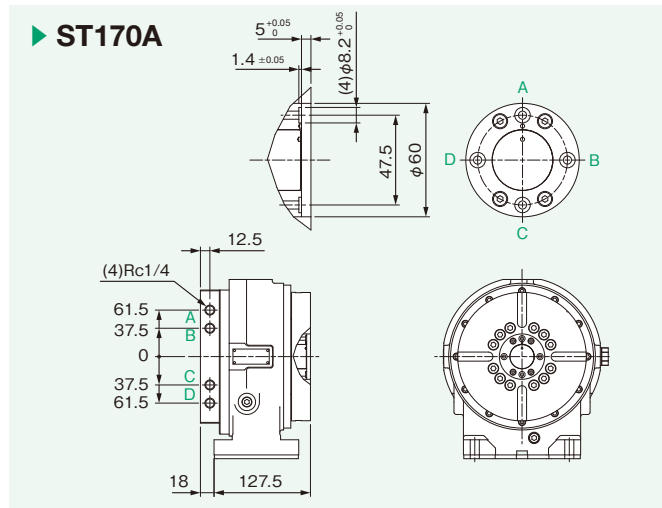

External type

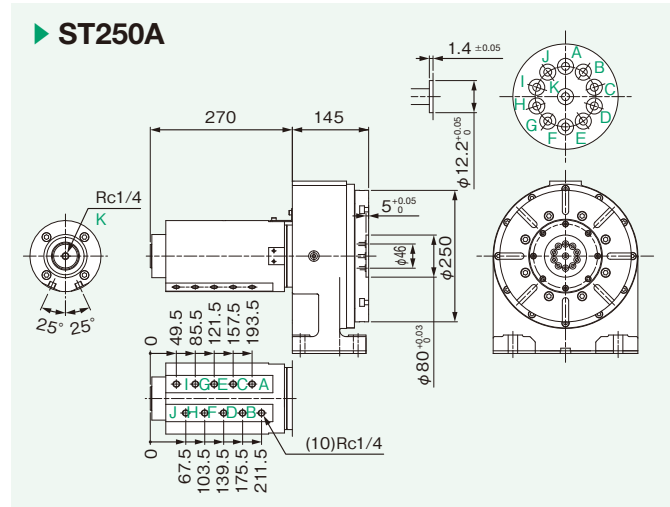
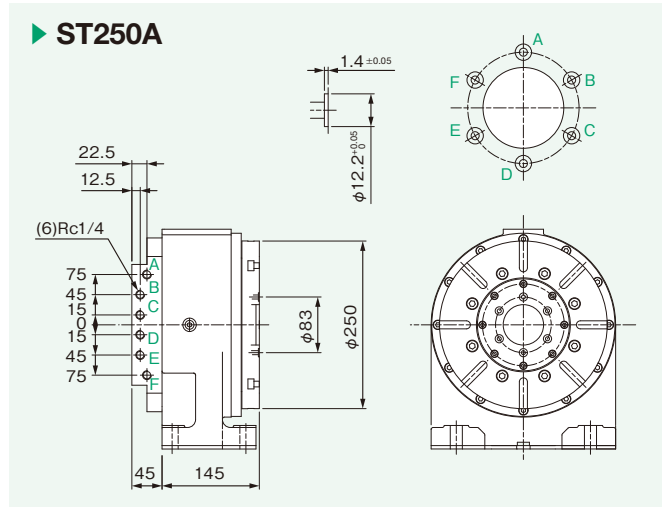
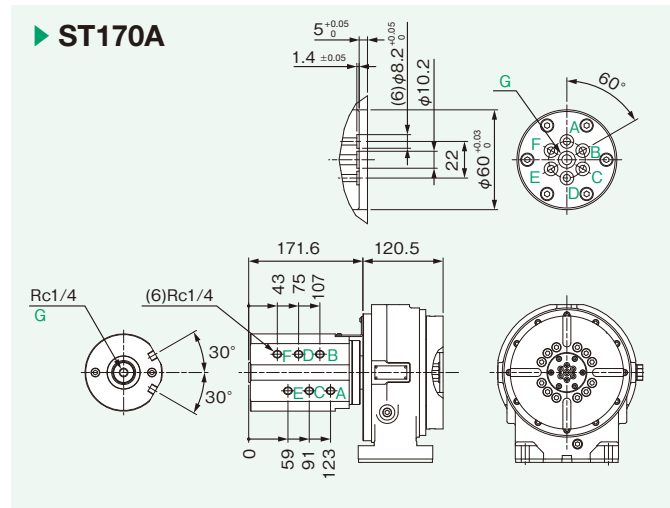

Auxiliary equipment — Tail stock dimensions

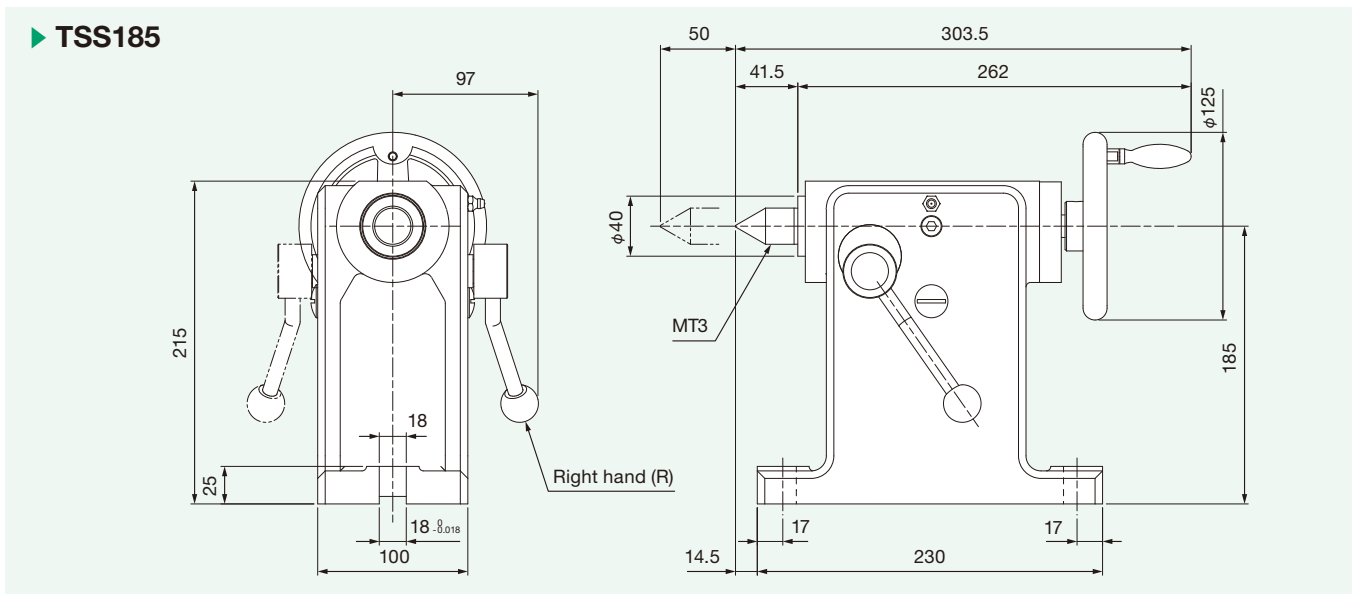
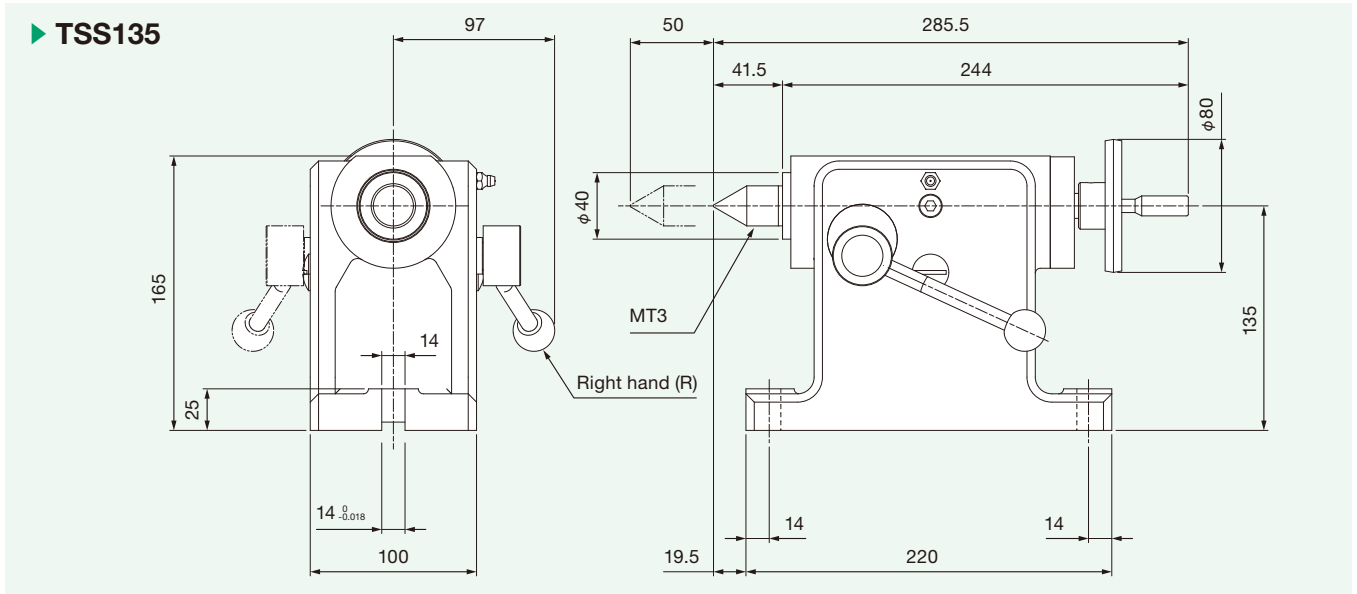

Serial and Product Code

Specifications / Dimensions

Mount clamps(Accessories) / Precision Ratings

Main unit options

Auxiliary equipment

Layout dimensions on machine

Precautions



Layout dimensions on machine

ACE CENTER MB-46VA/B [RCD200R (RCD170R)]

The drawings apply to the following specifications:
R side motor mounting, rear connector.

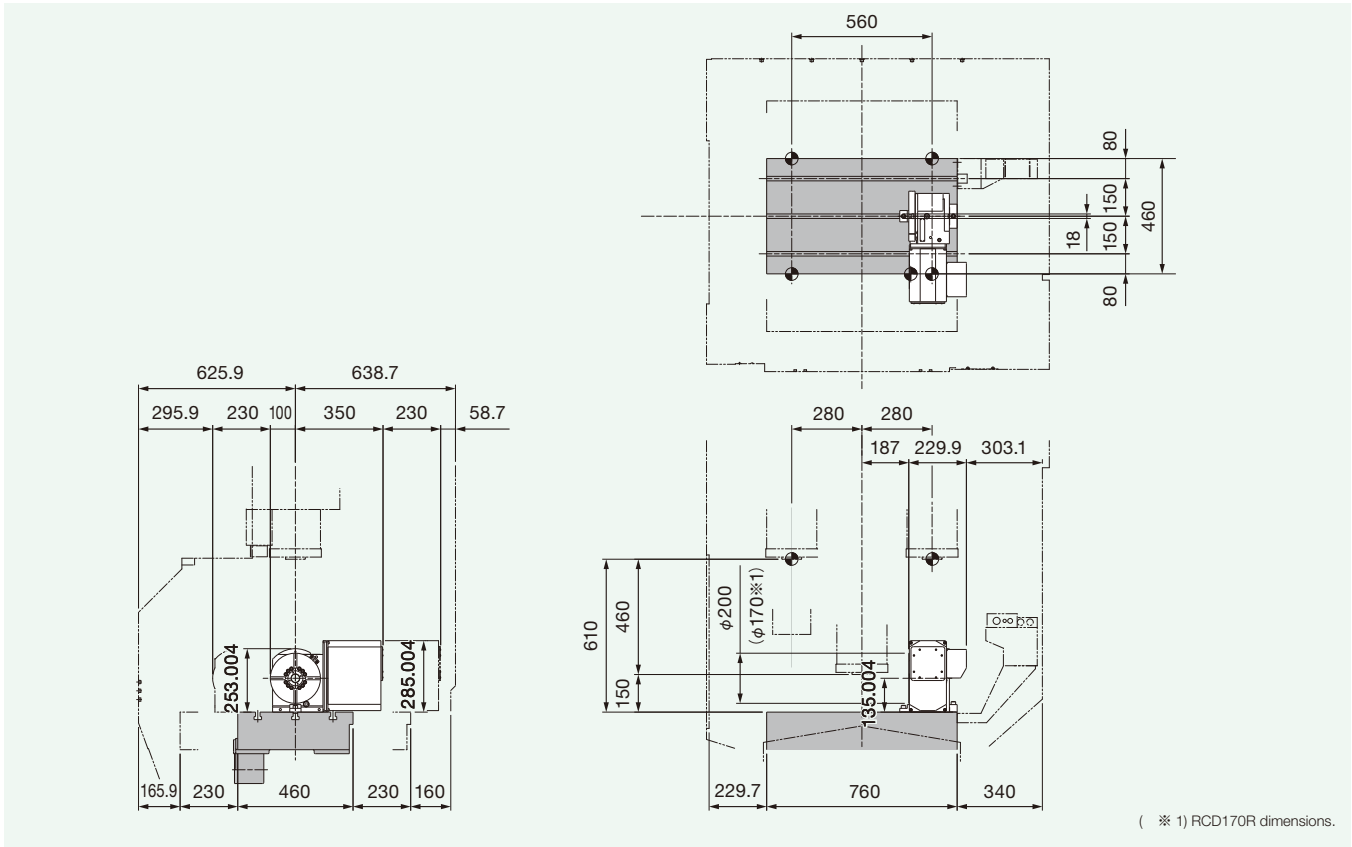

ACE CENTER MB-56VA/VB [RCD300R (RCD250R)]

The drawings apply to the following specifications:
R side motor mounting, rear connector.

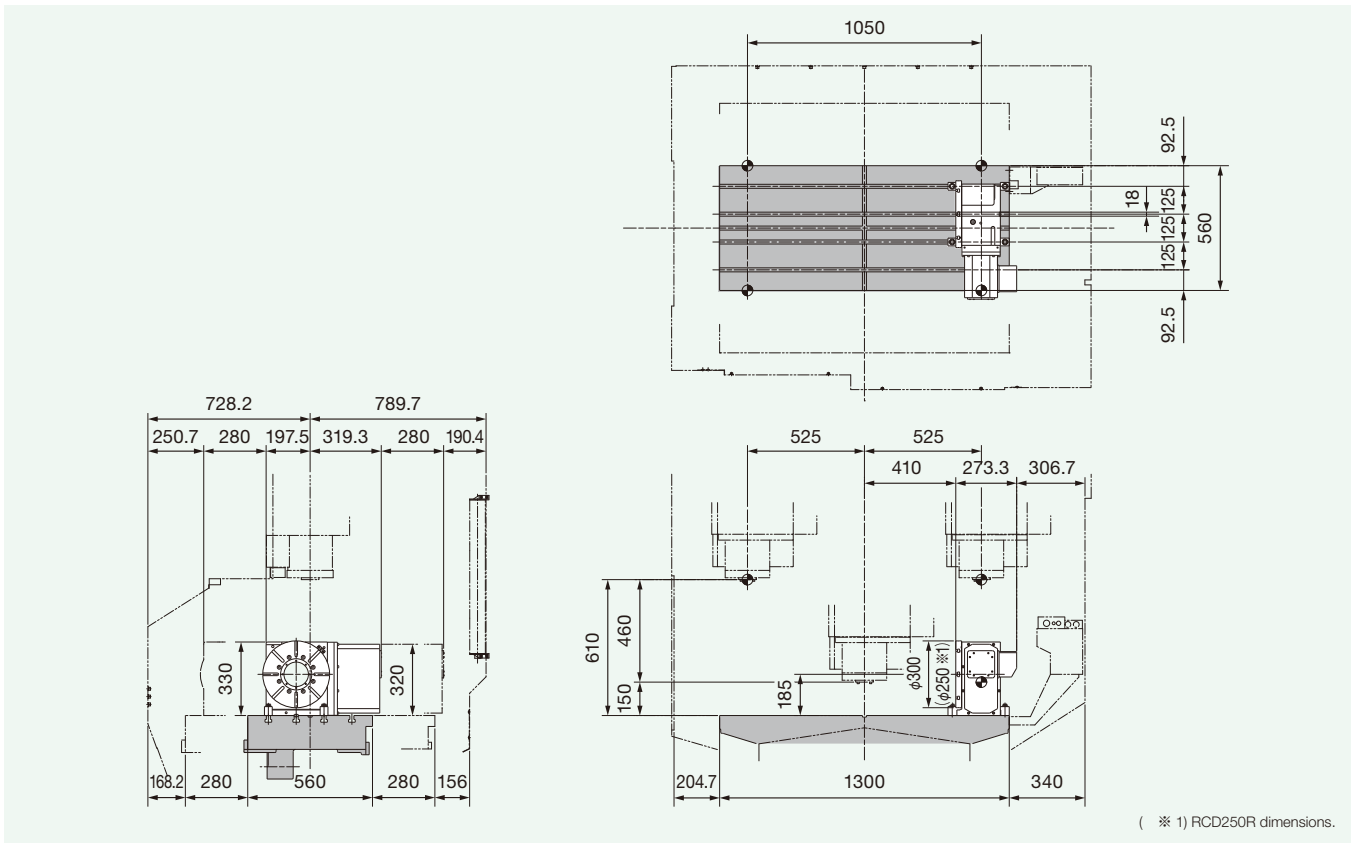

GENOS M460-VE [RCD200R (RCD170R)]

The drawings apply to the following specifications:
R side motor mounting, rear connector.

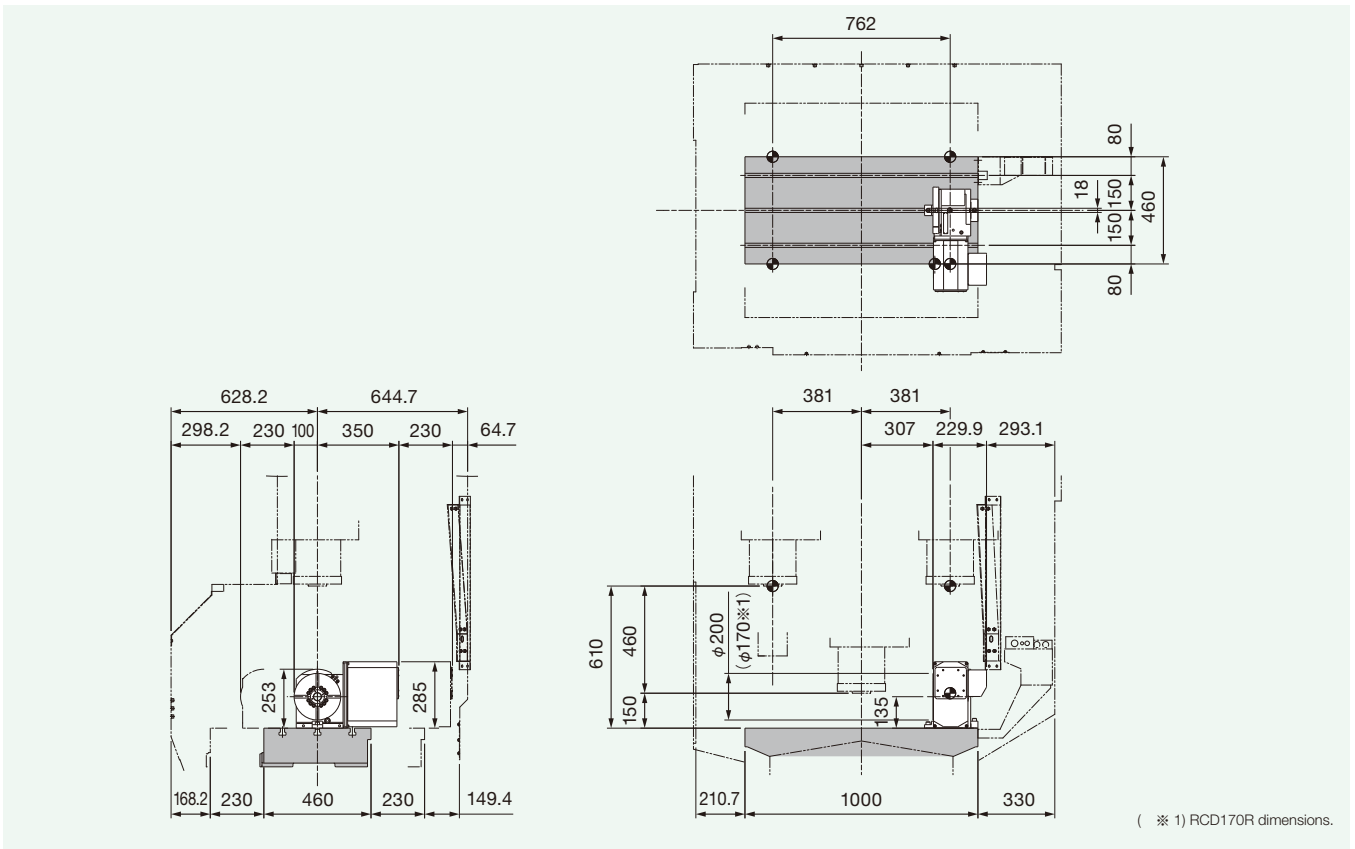

GENOS M560-V [RCD300R (RCD250R)]

The drawings apply to the following specifications:
R side motor mounting, rear connector.

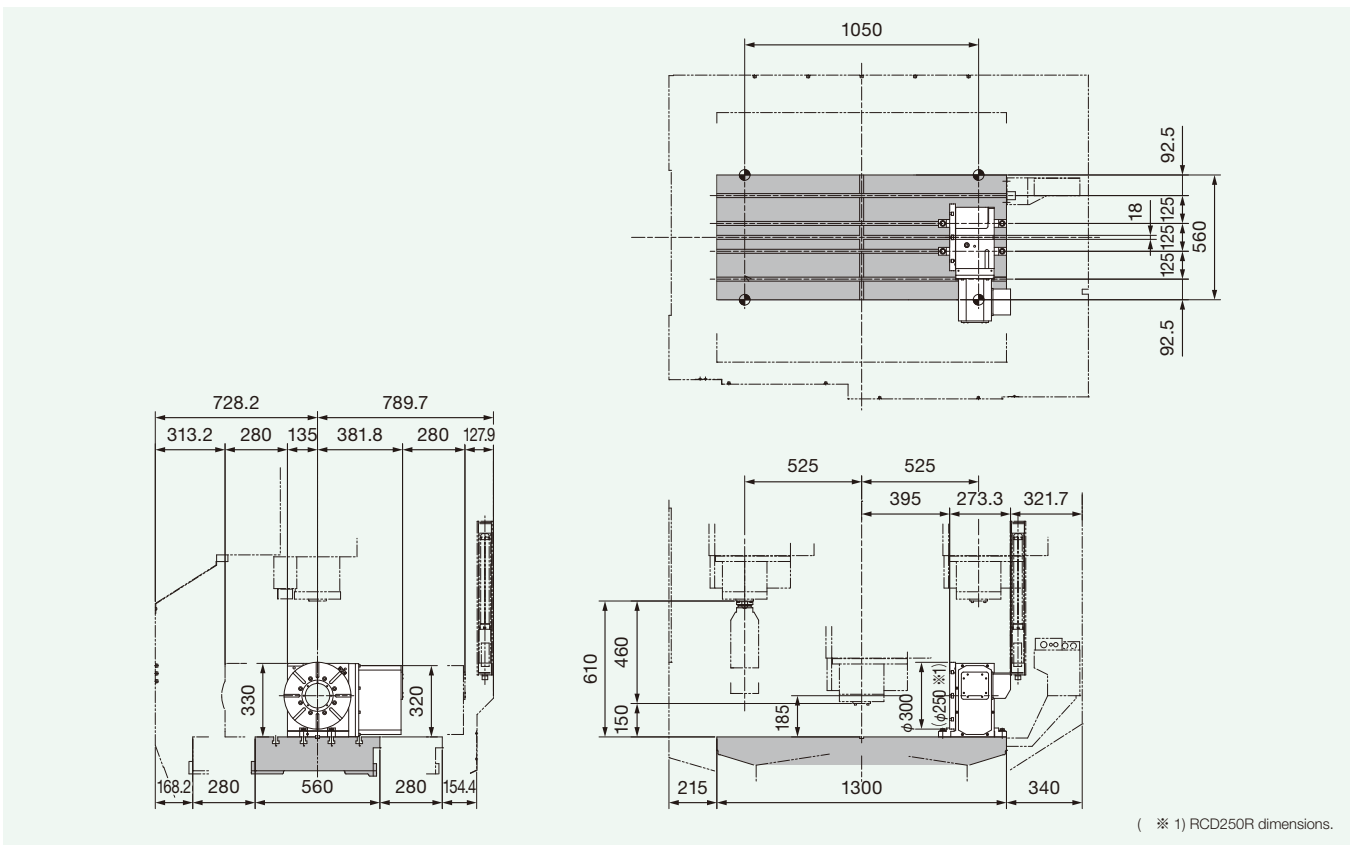

String and Product Code

Specifications / Dimensions

Mount clamps(Accessories) / Precision Ratings

Main unit options

Auxiliary equipment

Layout dimensions on machine

Precautions

Layout dimensions on machine

MILLAC 468V II [RCD300R (RCD250R)]

The drawings apply to the following specifications:
R side motor mounting, rear connector.

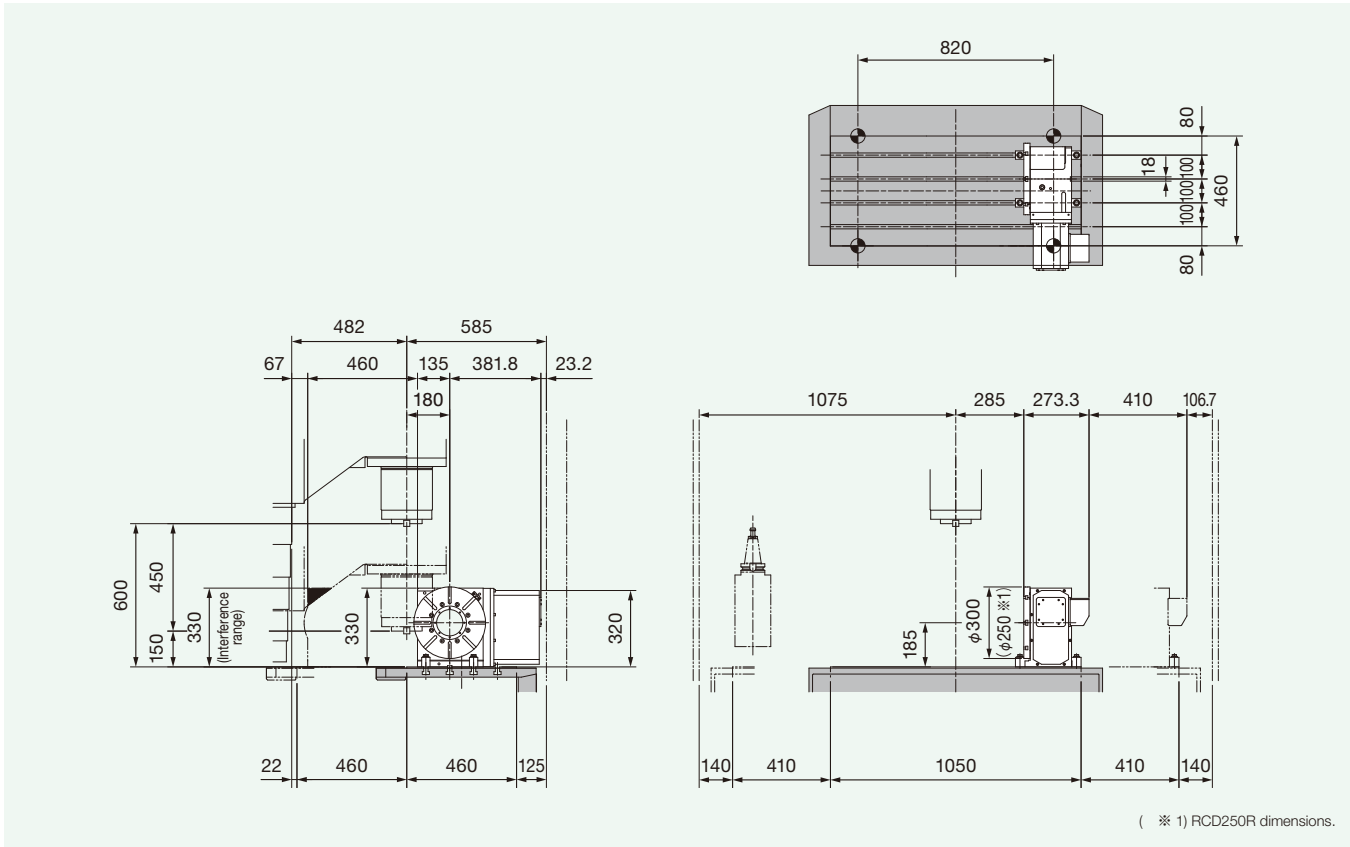

MILLAC 468V II [RT100R (BC axis)]

The drawings apply to the following specifications:
R side motor mounting, side connector.

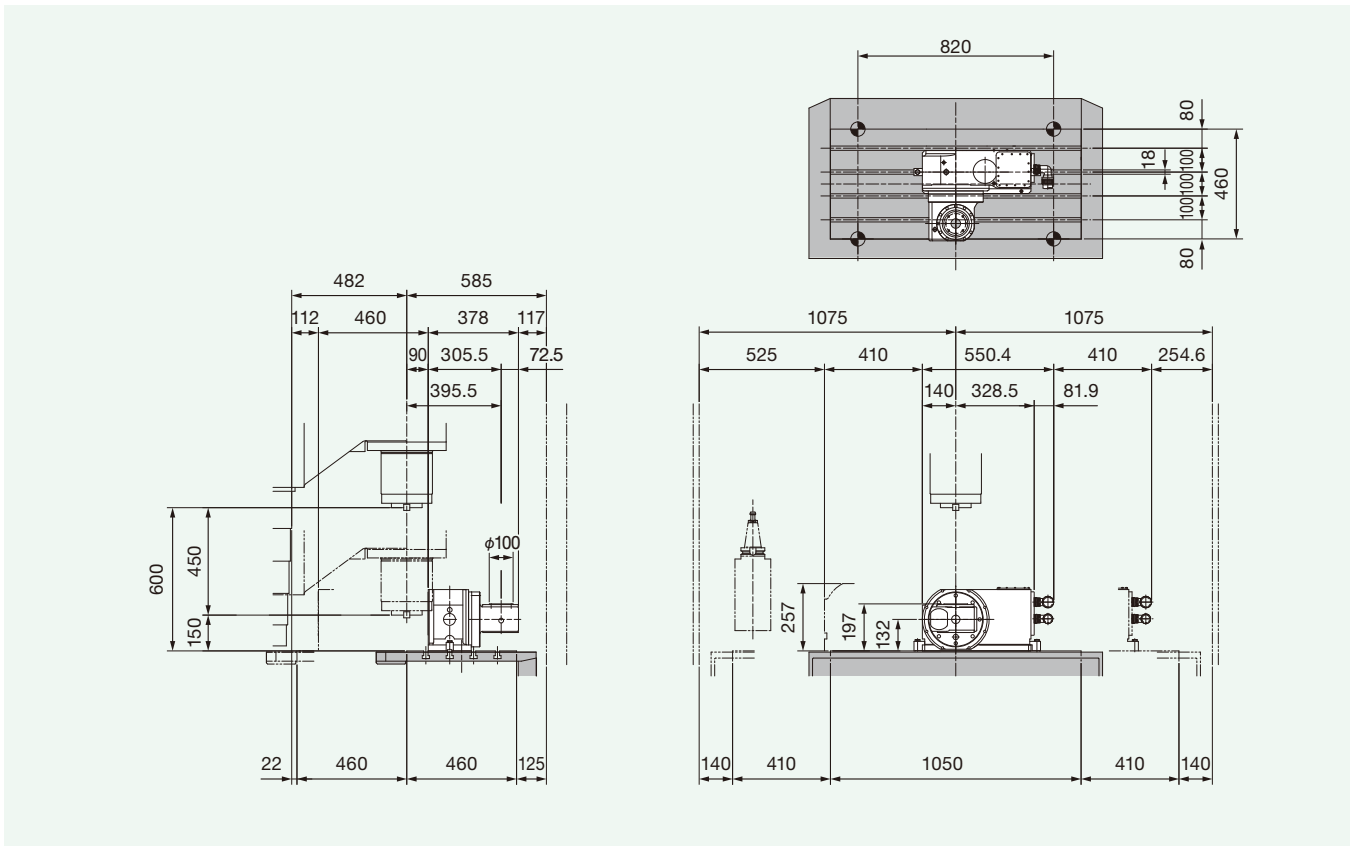

MILLAC 468V II [RT100R (AC axis)]

The drawings apply to the following specifications:
R side motor mounting, rear connector.

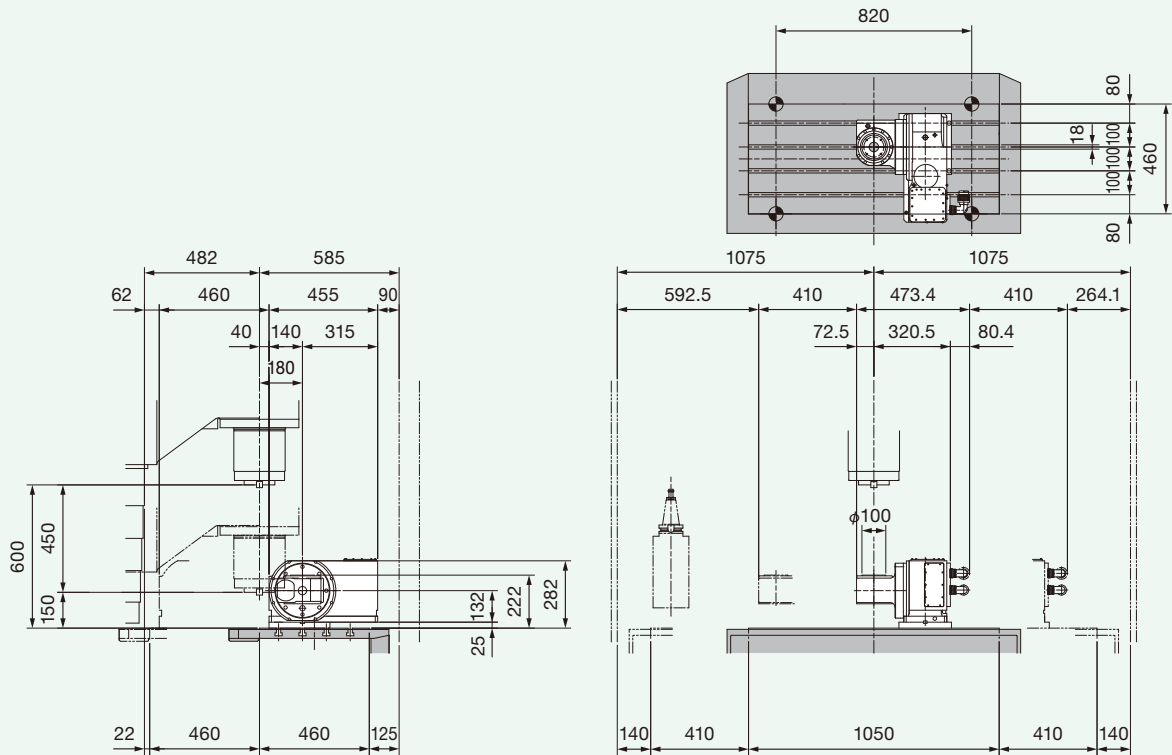

MILLAC 561V II [RCD300R (RCD250R)]

The drawings apply to the following specifications:
R side motor mounting, rear connector.

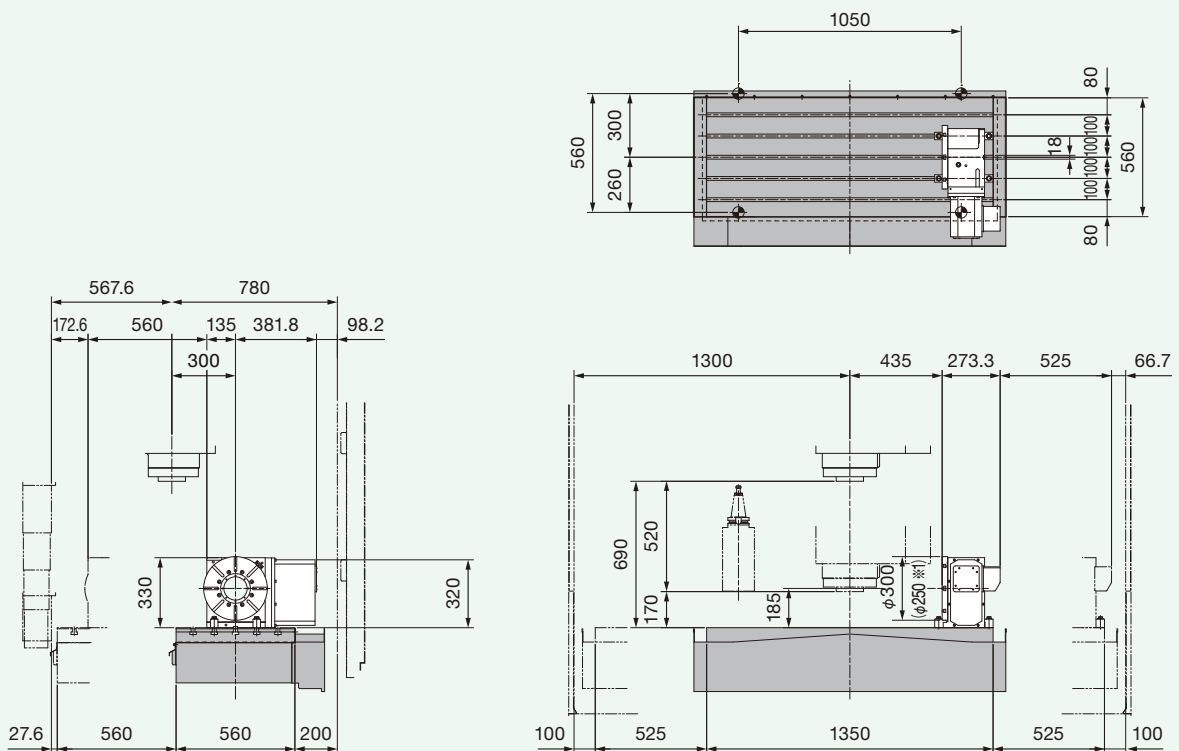

(※ 1) RCD250R dimensions.

Spring and Product Code

Specifications / Dimensions

Mount clamps (Accessories) / Precision Ratings

Main unit options

Auxiliary equipment

Layout dimensions on machine

Precautions



Layout dimensions on machine

MILLAC 561V II [RT100R (BC axis)]

The drawings apply to the following specifications:
R side motor mounting, side connector.

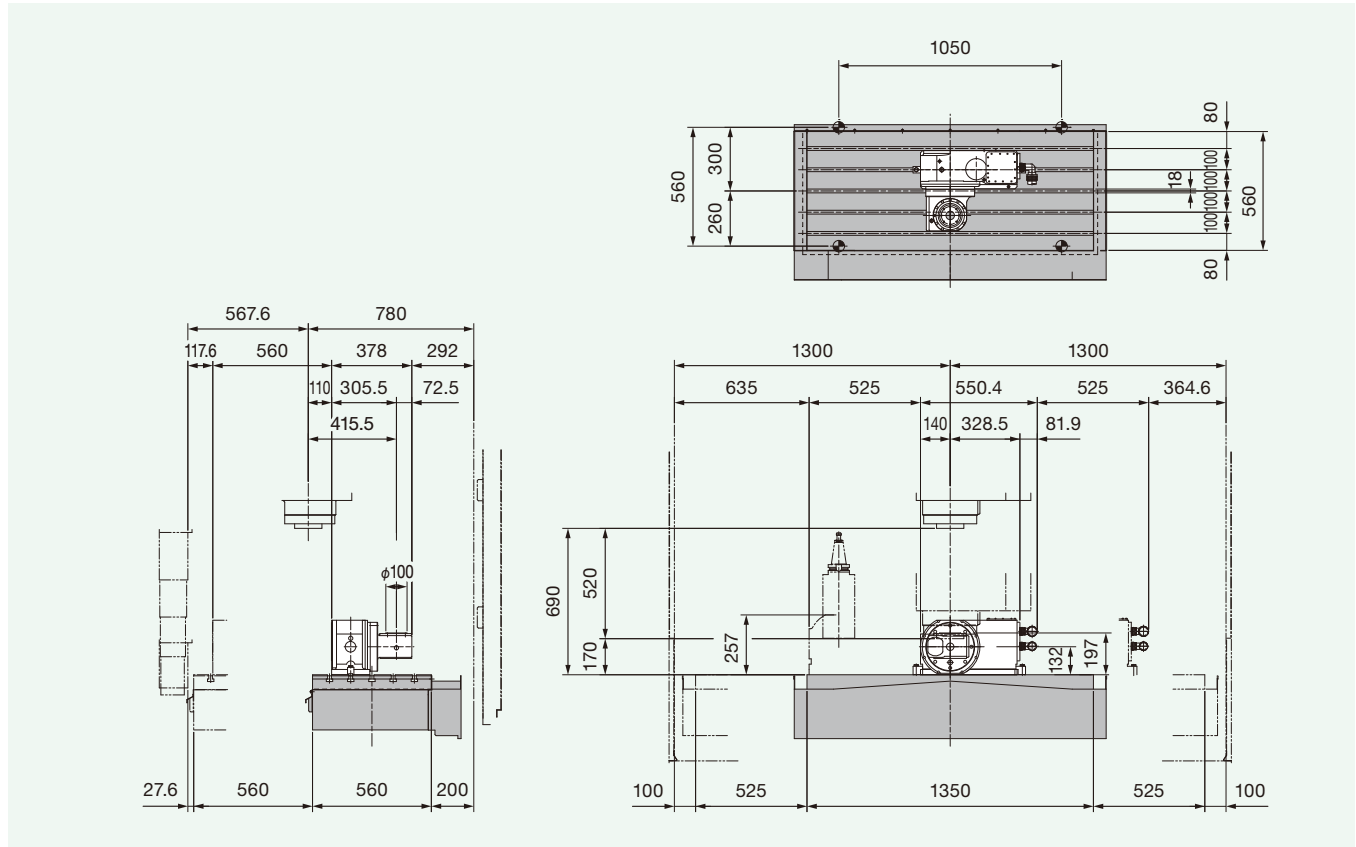

MILLAC 561V II [RT100R (AC axis)]

The drawings apply to the following specifications:
R side motor mounting, rear connector.

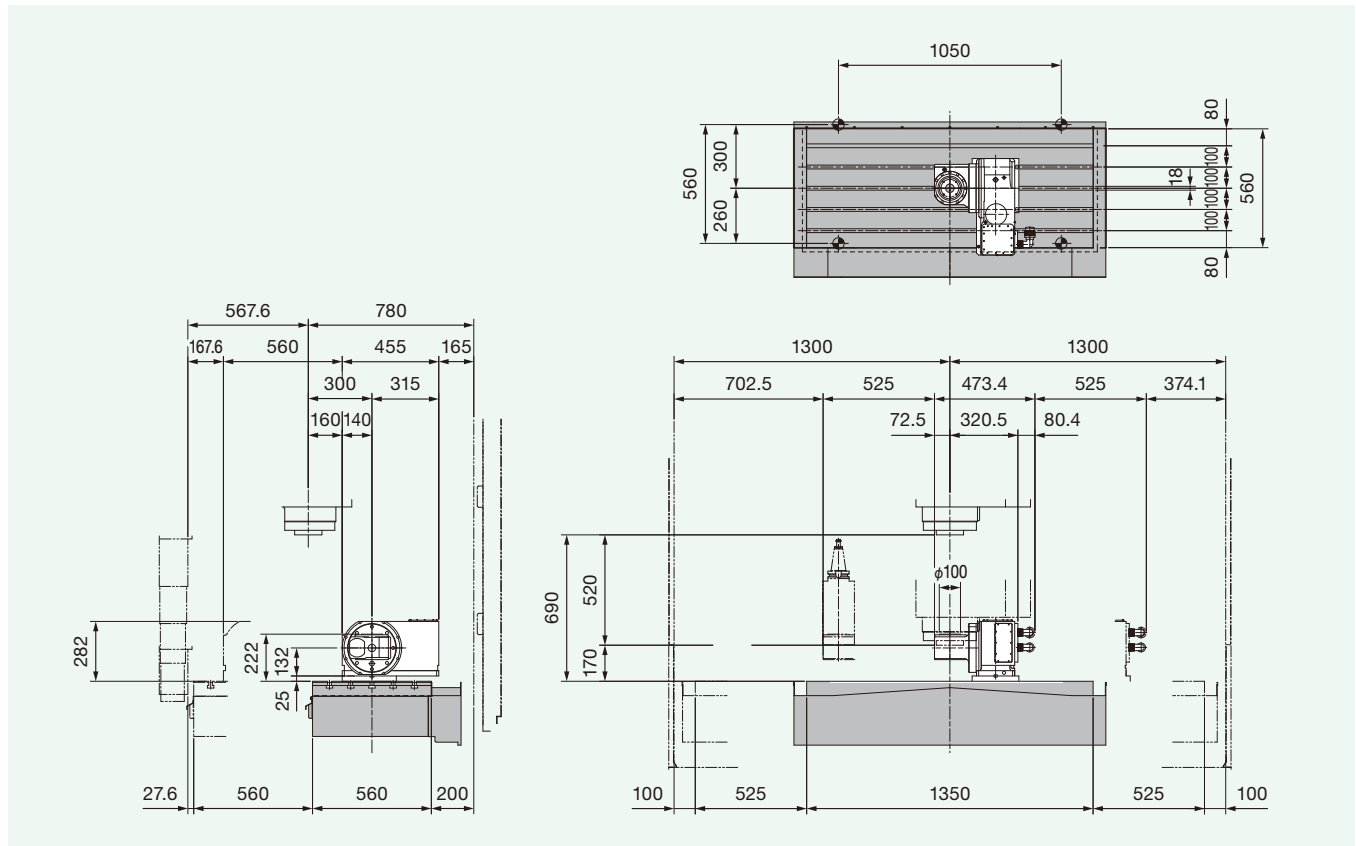

Precautions

▶ Air supply

Sankyo's CNC rotary tables come standard equipped with an air purge outlet. (Use it to blow out condensation and coolant to prolong the life of electrical parts and prevent rust in the motor housing.) Supply clean air for the air purge by referring to the drawing shown. (Do NOT block the exhaust outlet.)

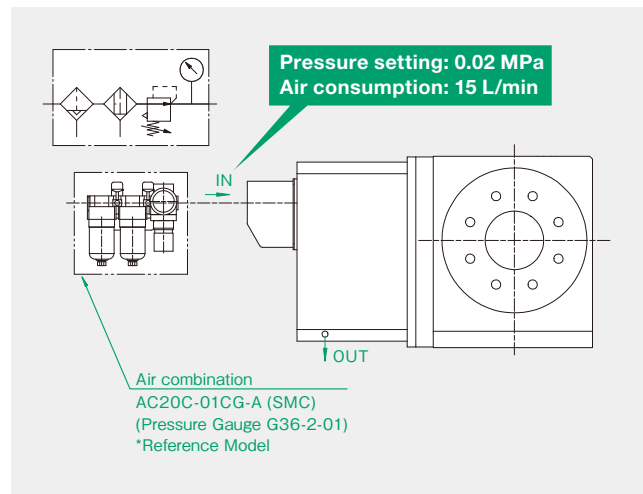

▶ Lubrication

Sankyo's CNC rotary tables use high-performance lubrication oil. Although the lubricant is chemically and thermally stable, it should be changed every 3,000 hours of operation in order to ensure longer product life. Even if operated less than 3,000 hours, the oil should be changed once per year. The condition of the oil can be checked with the oil level gauge while the unit is in the stop condition. Check the oil level and color. If the level is low or the color has changed, change the oil regardless of the number of operation hours. Some air bubbles may form in the oil during operation. This is normal and does not affect quality.

* Be sure to use only the lubricant specified below. Otherwise service life may be reduced and parts may deteriorate.

Specified lubricant: Mobil SHC629 (VG150)

▶ Use in grinding machines

When used in grinding machines, the seal device on the outer periphery of the table may become damaged. The warranty does not cover such damage.

▶ Maximum rotation speed

The maximum rotation speed for the table given in the specifications refers to the indexing speed. Consult with Sankyo if the table is to be rotated continuously. Otherwise, the table will heat up and lose accuracy, causing overload alarms with the servo motor.

▶ General Precautions

- Under the Japanese trade regulation, RollerDrive CNC can be restricted to supply or export to a country which may produce weapons or related products.
- Dimensions and specifications are subjected to be modified without notice.
- Contents of this catalogue is published in March 2021.
- Whole or part of the contents, mechanisms, logos, drawings belongs to Sankyo-Seisakusho, Japan. No part of the catalogue is allowed to copy or redistributed to the third party without the permission of Sankyo Seisakusho.

Global network

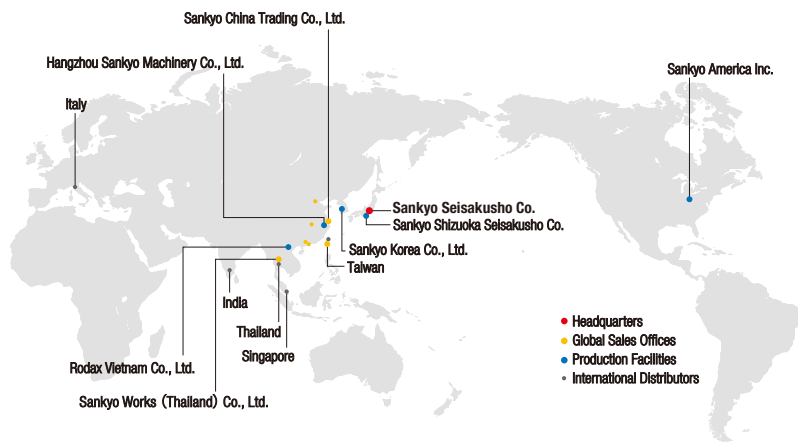

Group Companies

Sankyo America Inc.

10655 State Route 47 Sidney, Ohio, 45365 U.S.A.
 Phone: +1-(0)937-498-4901 Fax: +1-(0)937-498-9403
 Email: sales@sankyoautomation.com

Sankyo Korea Co., Ltd.

1449-48 Seobu-ro, Gwonseon-gu, Suwon-si, Gyeonggi-do, 16643 Korea
 Phone: +82-(0)31-895-5991 Fax: +82-(0)31-895-6607
 Email: kr-sales@rollerdrive.com

Sankyo China Trading Co., Ltd.

[Shanghai Sales Office]
 Room 1103, Block B, No.391 Guiping Road,
 Shanghai 200233 China
 Phone: +86-(0)21-5445-2813 Fax: +86-(0)21-5445-2340
 Email: sales@sankyochina-trading.com

[Shenzhen Sales Office]

Unit 19J, Tower B, NEO Building, No.6009 Shennan Avenue,
 Futian District, Shenzhen China
 Phone: +86-(0)755-8230-0270 Fax: +86-(0)755-8236-4605

[Tianjin Sales Office]

Room 1905, Pengzhanfeiwo Building A, Crossing Yale Road Yaolin Road,
 Xiqing District, Tianjin 300380 China
 Phone: +86-(0)22-2312-1005 Fax: +86-(0)22-2312-1007

[Guangzhou Sales Office]

Room 913, Xing Pu building, No.12 Guan Hong Road,
 Guangzhou Economic Development Zone, Huang Pu, Guang Zhou 510670 China
 Phone: +86-(0)20-8985-1846 Fax: +86-(0)20-8225-7346

[Wuhan Sales Office]

Room 2301, Taihe Square, No.134 Wusheng Road, Wuhan,
 Hubei Province China
 Phone: +86-(0)27-8568-5818 Fax: +86-(0)27-8568-2818

Hangzhou Sankyo Machinery Co., Ltd.

No.2518 Jiang Dong 2 Road, Hangzhou Jiang Dong Industrial Park,
 Xiaoshan Zone, Hangzhou, Zhejiang, China
 Phone: +86-(0)571-8283-3311 Fax: +86-(0)571-8283-1133

Rodax Vietnam Co., Ltd.

Plot No. M1, Thang Long Industrial Park II
 Di Su, My Hao, Hung Yen, Viet Nam
 Phone: +84-(0)221-3-589701 Fax: +84-(0)221-3-589708

Sankyo Works (Thailand) Co., Ltd.

9/31 Moo 5, Phaholyotin Road, Klongnueng,
 Klong Luang, Patumthani 12120 Thailand
 Phone: +66-(0)2-516-5355 Fax: +66-(0)2-068-0931
 Email: sales@sankyo-works.co.th

Contact us

Mon-Fri AM8:30-12:00 PM13:00-17:30 UTC + 09:00 (JST) (Except public holidays and company holidays)

■ **Headquarters**
(International Sales Division) 3-37-3 Tabatashinmachi, Kita-ku, Tokyo, Japan 114-8538
 Phone: +81-(0)3-3800-3330
 Fax: +81-(0)3-3800-3380
 Email: overseas@sankyo-seisakusho.co.jp
 URL: <http://www.sankyo-seisakusho.co.jp>

■ **Taiwan Sales Office** No.21, Ln.152, Jianxing Rd., Sanhe Vil., Daya Dist., Taichung City 42876, Taiwan (R.O.C.)
 Phone: +886-(0)4-2359-4048
 Fax: +886-(0)4-2359-4720
 Email: tw-sales@rollerdrive.com



<http://www.sankyo-seisakusho.co.jp>

* Photos of the Machining Center are used courtesy of Okuma Corporation.
 Sankyo Seisakusho is responsible for the manufacture of the CNC Rotary Table and CNC Tilting Table.
 * All patent rights and copyrights for parts of mechanisms described in this catalog and for trademarks, images, drawings etc. belong to Sankyo Seisakusho Co.
 "RollerDrive" is a registered trademark of Sankyo Seisakusho Co. in Japan.