

CNC ROTARY TABLE

RollerDrive CNC™

 **RCD, RT series**

For ROBODRILL from FANUC

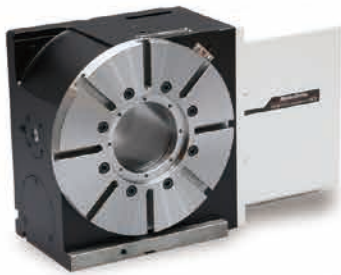

The Ultimate CNC Rotary Table



Zero-backlash Technology Delivers Unsurpassed Motion

The RollerDrive CNC is a rotary table designed to meet the requirements of machine tool manufacturers for greater speed and accuracy. The RollerDrive—Sankyo's zero-backlash reducer—delivers accurate output motion that stands up to external disturbances, unlike gearmotors or torque motors. It offers excellent rotary positioning accuracy of 10 seconds or less, and can hold up to heavy cutting forces on hard steel.

The heavy-duty RollerDrive CNC has no internal part wear and no loss of accuracy over long-term use, thus eliminating the need for regular calibration or adjustments.

Theory of Operation of the RollerDrive

The RollerDrive uses the roller gear mechanism, one of the finest motion control mechanisms available. The unit is constructed from an input shaft (the roller gear cam) and a turret (output shaft) fitted with roller followers. The roller followers are preloaded against a screw-like input shaft to completely eliminate backlash. Our proprietary adjustment mechanism provides optimum preload.

The roller followers planted in the turret use internal roller bearings to transfer torque while rotating. This ensures zero backlash, outstanding precision, and excellent efficiency without causing wear, while providing long-term consistent accuracy.

Exclusive zero-backlash construction

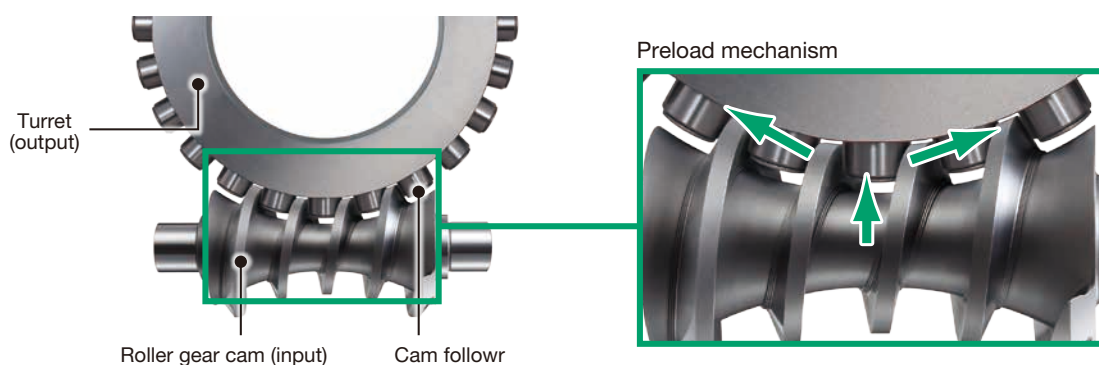

Features

➤➤ **Rolling contact**

➤➤ **Preload**

- ✓ No backlash (play).
- ✓ High accuracy and good efficiency.
- ✓ Preloadable for high rigidity.
- ✓ Clamless machining reduces positioning time.
- ✓ No deterioration of accuracy over time, initial accuracy is maintained for an extended period.

No Maintenance and Excellent Price Performance

Consistent long-term accuracy without maintenance.

► **Worm gear models**

Accuracy declines over time. Requires maintenance to achieve initial accuracy.

► **RollerDrive**

Accuracy is consistent with no maintenance even after 5 million operation cycles.

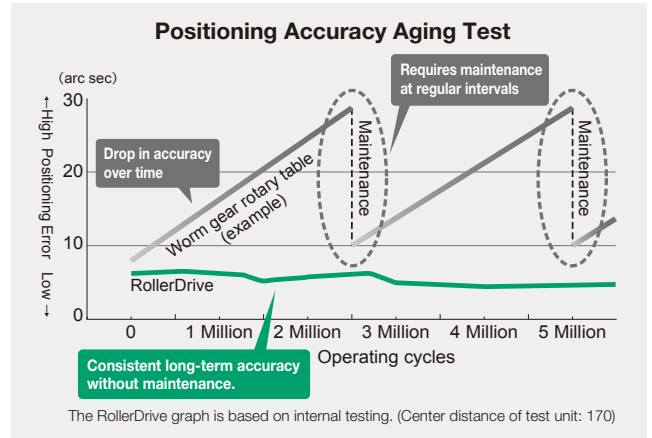

Cost Comparison with a Worm Gear Rotary Table

Offers Long-term Use without Maintenance

► **Worm gear models**

Maintenance costs occur once or twice a year to adjust the backlash.

► **RollerDrive**

Long-term use is possible without any mechanical maintenance. **Beats the cost of a worm gear even after adding annual running costs to the initial investment cost. Price performance continues thereafter.**

(Based on internal calculations.)

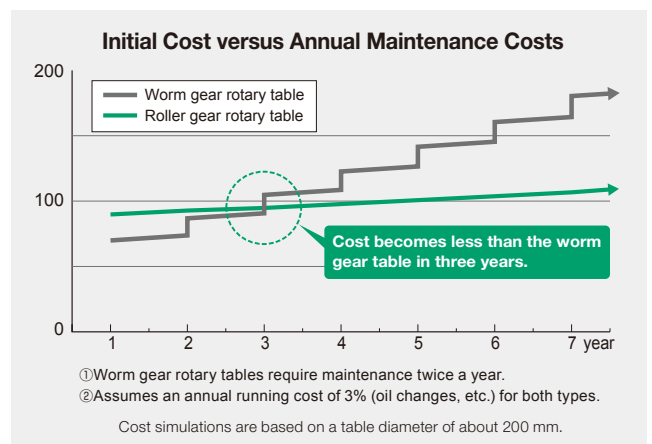

Shorter positioning time

Time comparison for 90° positioning

► **Conventional worm gear**

Clamping using hydraulic pressure or air pressure is required to suppress backlash.

► **RollerDrive**

Zero backlash and high rigidity eliminate the need for clamping. Compared to the worm gear type, positioning time is reduced to about one third.

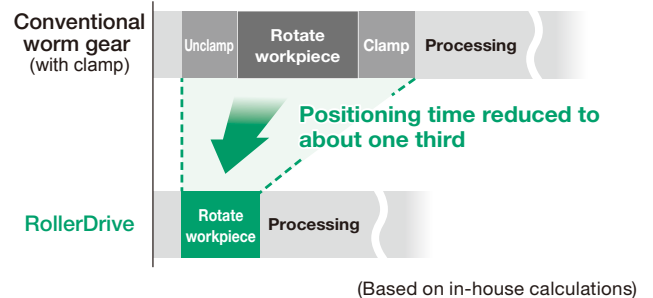

Extended Accuracy

Compared against a worm gear for over 5 million indexes.

► **Test conditions**

- Table size: Output table diameter: 170 mm
- Load inertia: 0.5 kgm²
- Index angle: 36° (unidirectional)
- Indexing time: 0.35sec

► **Results after 5 million indexes:**

Item	Worm gear	RollerDrive
Variation in positioning accuracy	24.2sec	0.9sec
Backlash (measured at R60)	18 μm (15 μm → 33 μm)	-

(Based on internal testing data.)

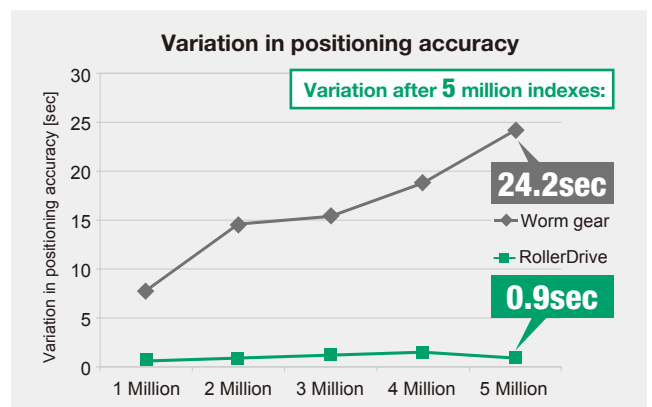

Sizing and Product Code

CNC Rotary Table Selection Chart

CNC Rotary Table		ROBODRILL		
		α -D21/14SiB	α -D21/14MiB	α -D21/14LiB
1-axis	RCD105	○		
	RCD170	○	○	○
	RCD200	○*	○*	○*
	RCD250		○*	○*
	RCD300		○*	○*
2-axis	RT100		○	○

* Contact Sankyo if you are interested in installing the α iF8 series motor in your rotary table.



Product Code [1-axis Series]

Rotary table

1	RCD105		2	A		3	R		4	B		5	F		6	1		
1	Model		2		3		4		5		6		7		8			
Servo motor		Motor mounting side		Connector position		Connector type		Table shape		Options		Standard / Custom						
With brake										High-accuracy model ^{*2,*3}		Air / Hydraulic clamping		Rotary joint ^{*2,*3}				
RCD105	A	FANUC	R	Right	B	Rear	F	Flexible	1	Tapped holes	E	With MP scale	C	With clamp	J	Internal type	Blank	Standard
RCD170			L	Left	S	Side			2 ¹	T slot	Blank	None	Blank	None	H	External type	X	Custom
RCD200															Blank	None		
RCD250																		
RCD300																		

*1 For RCD105, the T slot table cannot be selected.
 *2 There is no hollow bore in the table when the MP scale (high-accuracy model) or rotary joint is installed.
 *3 Simultaneous installation of MP scale (high-accuracy model) and rotary joint is not supported.

Motor mounting side	Connector position	Connector type / shape	Table shape																		
R	B	F	1																		
L	S	S : Straight A : Angled	<table border="1"> <thead> <tr> <th></th> <th>A</th> <th>B</th> </tr> </thead> <tbody> <tr> <td>RCD105</td> <td>(4)M8×1.25, 16DP</td> <td>75</td> </tr> <tr> <td>RCD170</td> <td>(8)M8×1.25, 14DP</td> <td>140</td> </tr> <tr> <td>RCD200</td> <td>(8)M8×1.25, 14DP</td> <td>170</td> </tr> <tr> <td>RCD250</td> <td>(8)M10×1.5, 18DP</td> <td>210</td> </tr> <tr> <td>RCD300</td> <td>(8)M10×1.5, 18DP</td> <td>250</td> </tr> </tbody> </table>		A	B	RCD105	(4)M8×1.25, 16DP	75	RCD170	(8)M8×1.25, 14DP	140	RCD200	(8)M8×1.25, 14DP	170	RCD250	(8)M10×1.5, 18DP	210	RCD300	(8)M10×1.5, 18DP	250
	A	B																			
RCD105	(4)M8×1.25, 16DP	75																			
RCD170	(8)M8×1.25, 14DP	140																			
RCD200	(8)M8×1.25, 14DP	170																			
RCD250	(8)M10×1.5, 18DP	210																			
RCD300	(8)M10×1.5, 18DP	250																			
			2 ¹ P6: Table with RCD dimensions																		

Support table

1	ST105A		2	C		3	J		4	X	
1	Model		2		3		4		Options		
Air / Hydraulic clamping		Rotary joint		Standard / Custom							
ST105A	For RCD105	C	With clamp	J	Internal type	Blank	Standard				
ST170A	For RCD170 and RCD200	Blank	None	H	External type	X	Custom				
ST250A	For RCD250 and RCD300			Blank	None						

Tail stock

1	TSS105		2	M		3	R		4	X	
1	Model		2		3		4		Standard / Custom		
Type		Handle side									
TSS105	For RCD105	M	Manual	R	Right	Blank	Standard				
TSS135	For RCD170 and RCD200			L	Left	X	Custom				
TSS185	For RCD250 and RCD300										

Product Code [2-axis Series]

Rotary table



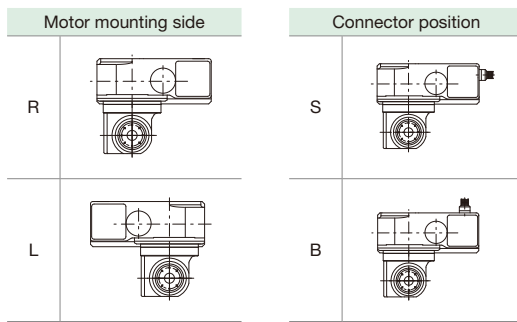

1	RT100	-	2	A	3	R	4	S
1			2		3		4	
Model			Servo motor		Motor mounting side		Connector position	
RT100			A	FANUC	R	Right	S	Side
					L	Left	B	Rear

-	5	E	6	J
	5		6	
	Options			
	High-accuracy model ^{*1}		Rotary joint (Internal type) ^{*2}	
	E	With MP scale	J	Internal type
	Blank	None	Blank	None

*1 There is no hollow bore in the table when the MP scale (high-accuracy model).
 *2 Use the rotary joint for the air supply. It is not suitable for supplying hydraulic oil.



Specifications [1-axis Series]

Specifications		RCD105	RCD170	RCD200	RCD250	RCD300	
Table diameter	mm	Φ105	Φ170	Φ200	Φ250	Φ300	
Table pilot bore diameter	mm	Φ60 ^{+0.03} ₀	Φ60 ^{+0.03} ₀	Φ60 ^{+0.03} ₀	Φ110 ^{+0.035} ₀	Φ110 ^{+0.035} ₀	
Center height	mm	105	135	135	185	185	
Table T slot width	mm	-	12 ^{+0.018} ₀	12 ^{+0.018} ₀	12 ^{+0.018} ₀	12 ^{+0.018} ₀	
Keyway width	mm	14. ⁰ _{0.011}	14. ⁰ _{0.011}	14. ⁰ _{0.011}	14. ⁰ _{0.011}	14. ⁰ _{0.011}	
Clamp type (air 0.5 MPa, hydraulic 3.5 MPa)		Air / Hydraulic	Air / Hydraulic	Air / Hydraulic	Hydraulic	Hydraulic	
Clamp torque ^{*1}	N·m	210	310	310	1100	1100	
Motor shaft equivalent inertia ^{*2,3}	×10 ⁻⁴ kg·m ²	0.56	2.96	3.15	5.70	5.70	
Motor model (FANUC)		αiS2/5000-B (A06B-2212-B400)	αiS4/5000-B (A06B-2215-B400)	αiS8/4000-B ^{*8} (A06B-2235-B400)	αiS8/4000-B ^{*8} (A06B-2235-B400)	αiS8/4000-B ^{*8} (A06B-2235-B400)	
Minimum setting unit	deg	0.0001	0.0001	0.0001	0.0001	0.0001	
Maximum table speed	min ⁻¹	100	70	70	60	60	
Gear ratio		1/50	1/50	1/50	1/60	1/60	
Indexing accuracy	arc.sec	±15	±15	±15	±10	±10	
Repeatability	arc.sec	8	8	8	4	4	
Net weight	kg	30	51	59	110	115	
Allowable payload	Upright position ^{*4} 	kg	50 (100)	70 (140)	70 (140)	255 (510)	255 (510)
	Horizontal position 	kg	100	140	140	510	510
Allowable load	F 	N	18200	21000	21000	52000	52000
	F×L with clamping 	N·m	210	310	310	1100	1100
	Continuous holding torque ^{*2,5}	N·m	122	236	416	512	512
	Maximum output torque ^{*2,5,6}	N·m	221	362	544	987	987
	F×L 	N·m	900	1300	1300	5500	5500
Allowable workpiece inertia	kg·m ²	0.5	1.1	1.1	8.3	8.3	
External rotary joint (number of ports) ^{*7}		6+1	6+1	6+1	10+1	10+1	
Internal rotary joint (number of ports) ^{*7}		4	6	6	8	8	
MP scale (high-accuracy model) ^{*7}		MPRZ-536A (MHI)					
		MPI-536A (MHI)					

*1 Values for RCD105, RCD170, and RCD200 are clamping torques when using an air hydro booster with a air pressure of 0.5 MPa as the supply source.

*2 Values for motor shaft equivalent inertia, gear ratio, and continuous / maximum holding torque are given for Fanuc motors. Please contact Sankyo if a different motor is to be used.

*3 Motor shaft equivalent inertia does not include the inertia of the motor shaft.

*4 The allowable payload value for upright mounting shown in brackets applies when a tail stock or support table is used.

*5 The continuous / maximum holding torque is the allowable load torque when a clamp is not used.

*6 Maximum holding torque should not exceed 10 seconds with 20% duty.

*7 Simultaneous use of the MP scale (high-accuracy model) and the rotary joint is not supported.

*8 Contact Sankyo if you are interested in installing the α iF8 series motor in your rotary table.

Dimensions [1-axis Series]

The drawings apply to the following specifications: R side motor mounting, rear connector.

Sizing and Product Code
Specifications / Dimensions
Mount clamps/accessories / Main unit options
Auxiliary equipment
Control methods for air / hydraulic table clamping
Layout dimensions on machine
Precision Ratings
Precautions

► RCD105

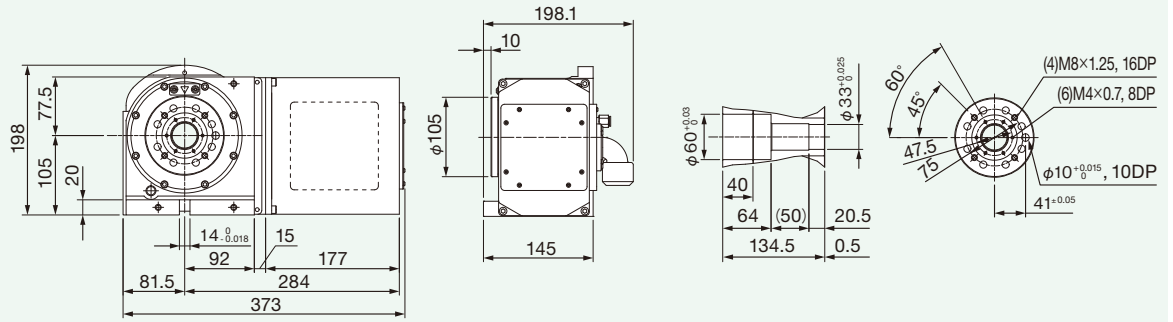

► RCD170

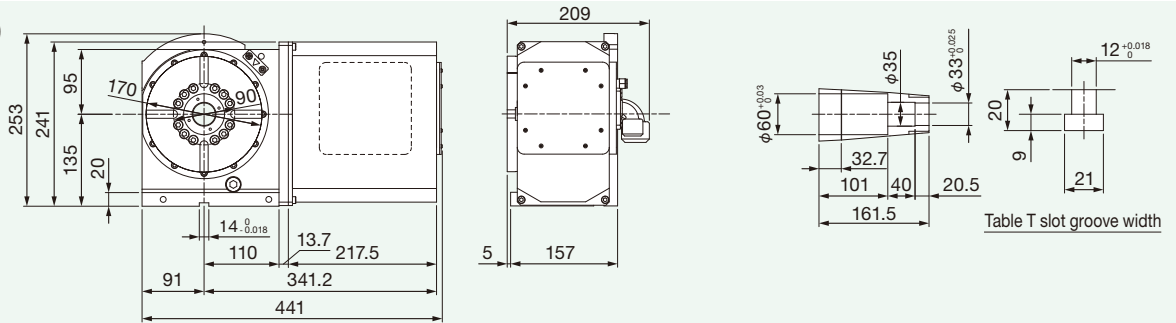

► RCD200

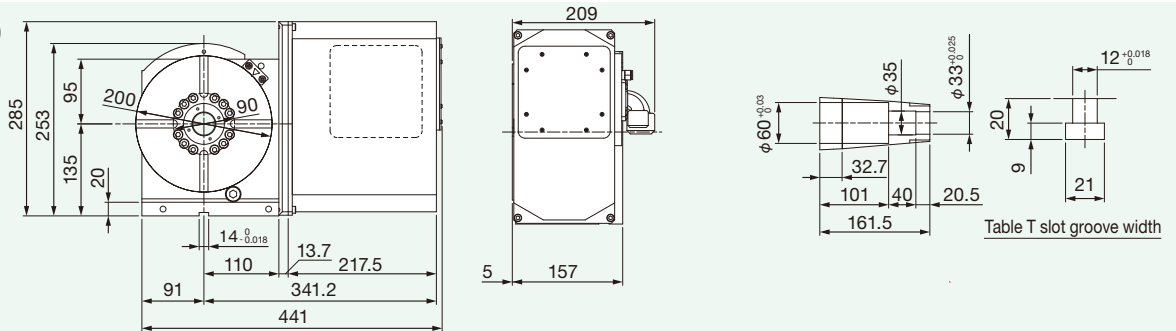

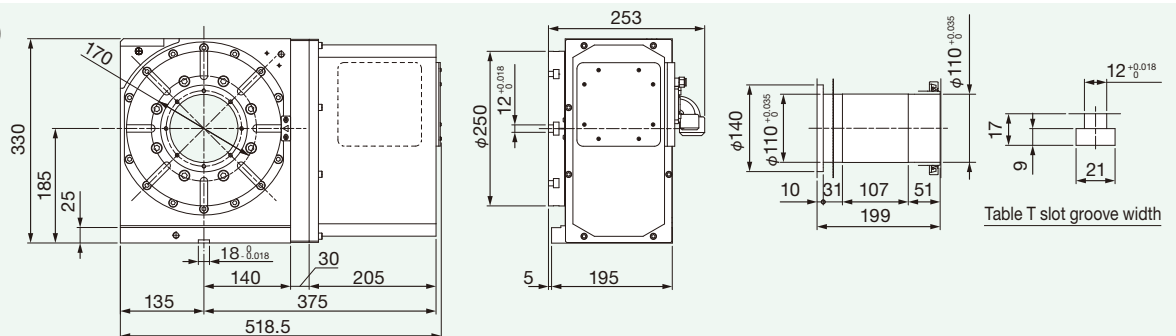

► RCD250

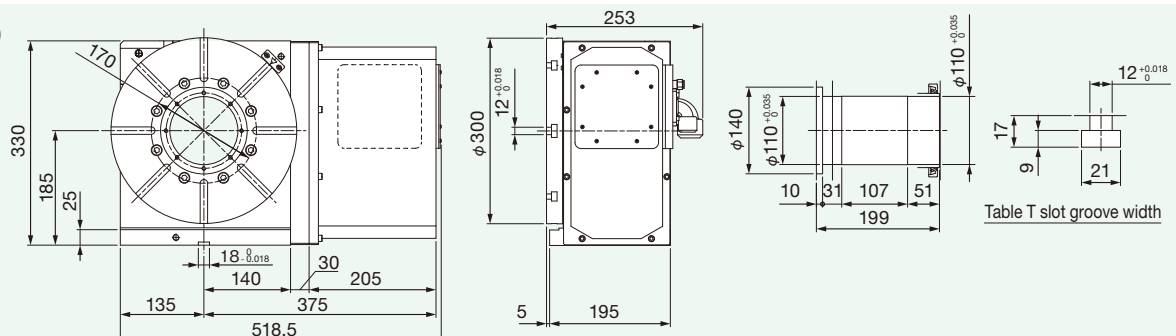

► RCD300

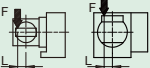
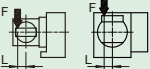
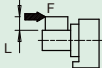

Specifications [2-axis Series]

Specifications		RT100		
		Rotary axis	Tilt axis	
Tilting angle	deg	-20 ~ +120		
Table diameter	mm	Φ100		
Table pilot bore diameter	mm	Φ40 ^{+0.025} ₀		
Center height (90 degrees)	mm	132		
Table surface height (0 degree)	mm	197		
Keyway width	mm	14 ⁰ _{-0.011}		
Motor shaft equivalent inertia ¹	×10 ⁻⁴ kg·m ²	0.92	1.98	
Motor model (FANUC)		αiS2/5000-B (A06B-2212-B000)	αiS4/5000-B (A06B-2215-B300)	
Minimum setting unit	deg	0.0001	0.0001	
Maximum table speed	min ⁻¹	100	55	
Gear ratio		1/48	1/90	
Indexing accuracy	arc.sec	±15	±10	
Repeatability	arc.sec	8	4	
Net weight	kg	91		
Allowable payload	0 degree 	kg	30	
	90 degrees 	kg	30	
Allowable load	F 	N	6016	
	F×L Continuous holding torque 	N·m	118	384
	F×L Maximum output torque ² 	N·m	213	611
	F×L 	N·m	290	
Allowable workpiece inertia	kg·m ²	0.1		
Internal rotary joint (number of ports) ³		2	-	
MP scale (high-accuracy model)		MPRZ-536A (MHI)	MPRZ-736A (MHI)	
		MPI-536A (MHI)	MPI-736A (MHI)	

*1 Motor shaft equivalent inertia does not include the inertia of the motor shaft.

*2 Maximum holding torque should not exceed 10 seconds with 20% duty.

*3 Use the rotary joint for the air supply. It is not suitable for supplying hydraulic oil.

Dimensions [2-axis Series]

The drawings apply to the following specifications: R side motor mounting, side connector.

► RT100

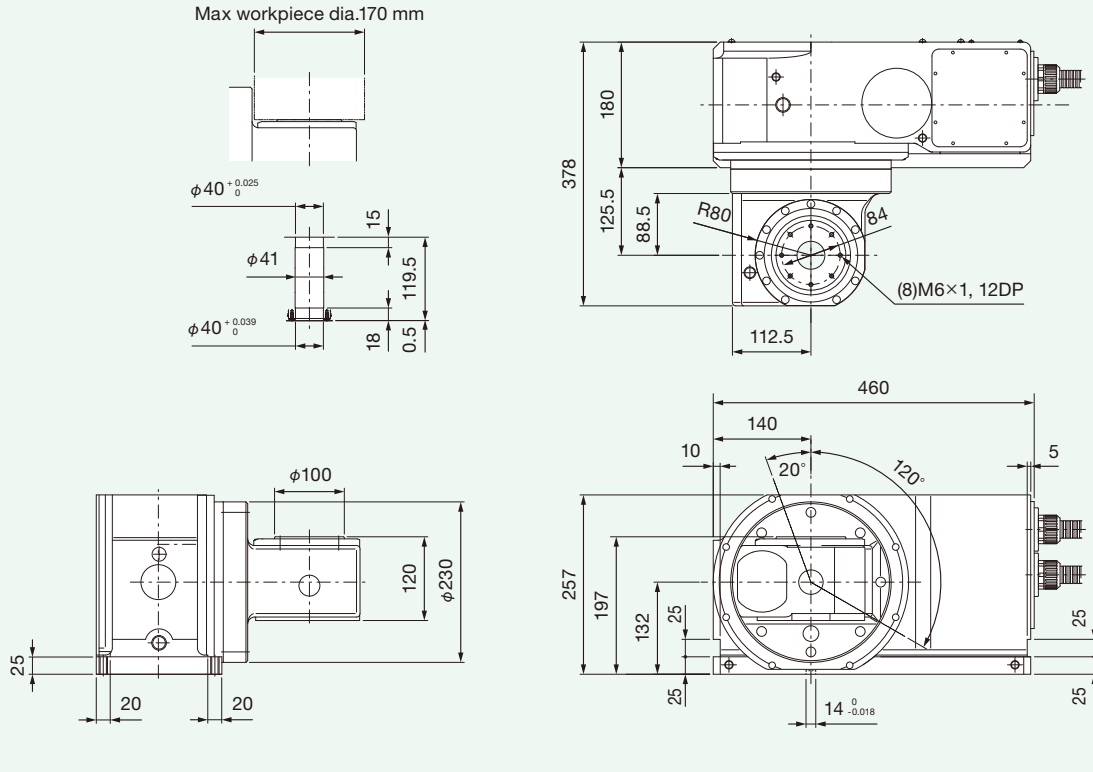

Workpiece interference region for tilting

	Tilting angle		
	-20° ~ 45°	-20° ~ 90°	-20° ~ 120°
RT100			

Sizing and Product Code

Specifications / Dimensions

Mount clamps/accessories / Main unit options

Auxiliary equipment

Control methods for air / hydraulic table clamping

Layout dimensions on machine

Precision Ratings

Precautions

Mount clamps (Accessories)

Model	Size	Mount clamps type / Qty. used
RCD	105	g, h (1 pc. each)
	170	g, h (1 pc. each)
	200	g, h (1 pc. each)
	250	i (4 pcs.)
	300	i (4 pcs.)
RT	100	b (4 pcs.)

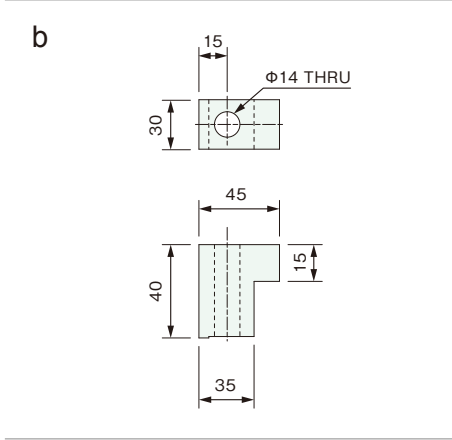
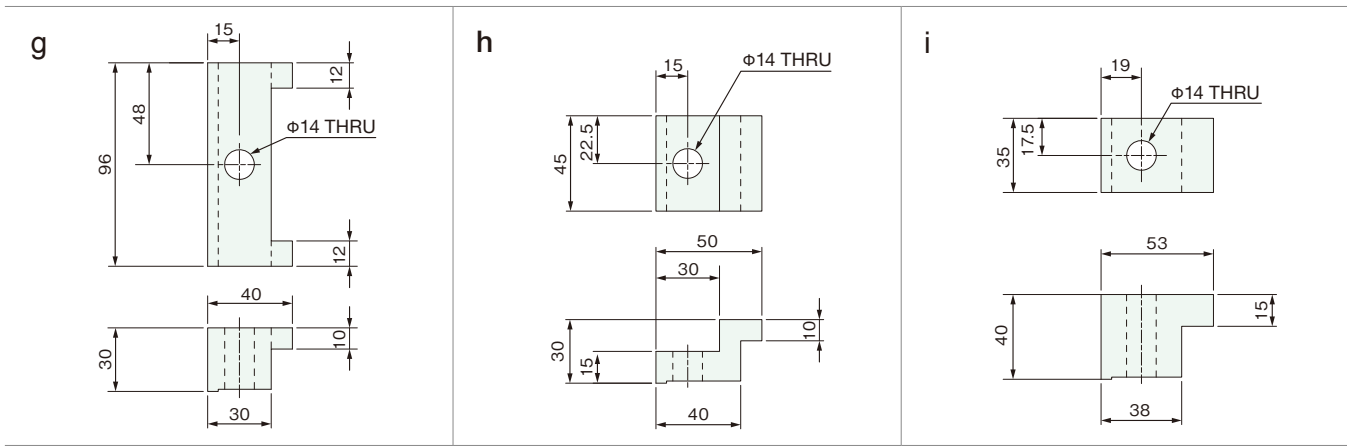

Main unit options — High-accuracy model

By mounting a commercially available MP scale (MHI) to the rotary table, fully closed loop control can be realized. Direct detection of the table's rotation angle enables indexing with high accuracy.

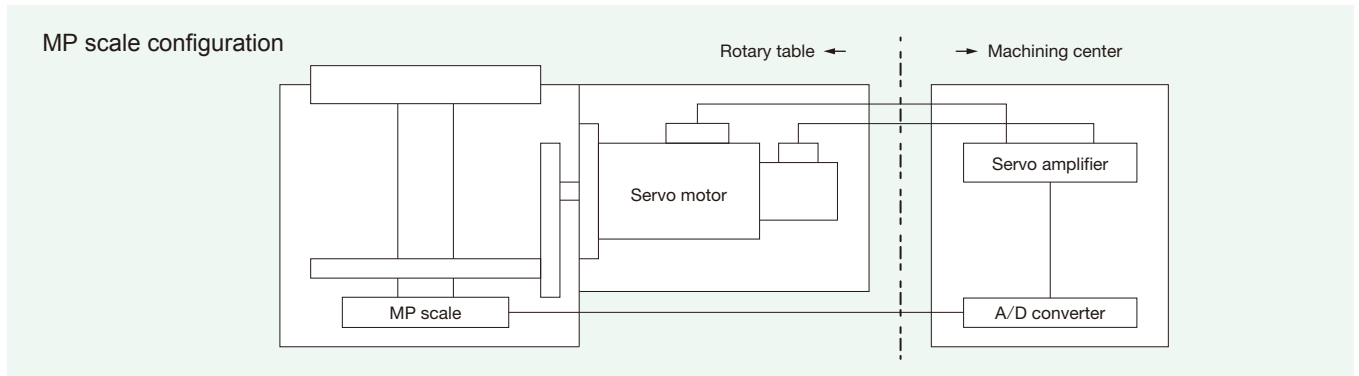

Notes

1. With the incremental specification, absolute detection is possible by combination with an absolute type servo motor.
2. Refer to the documentation of the respective manufacturer for operation instructions and information on the connection between the A/D converter and higher-level equipment.

Main unit options — Rotary joint

Specifications

Product type	Size	Max. number of ports		Maximum actuation pressure
		Internal type	External type	
RCD	105	4	6+1 ^{*1}	Fluid: Air 0.7 MPa / Hydraulic 6 MPa
	170	6	6+1 ^{*1}	
	200	6	6+1 ^{*1}	
	250	8	10+1 ^{*1}	
	300	8	10+1 ^{*1}	
RT	100	2	-	Fluid: Air 0.7 MPa ^{*4}

- *1 The +1 indicates the port in the center bore.
- *2 Make sure to furnish a line filter in the air supply line.
- *3 Under prolonged use a small amount of actuation oil may leak from the oil port toward the adjacent air port. If possible, the adjacent ports should be left open for use as drain ports.
- *4 Use the rotary joint for the air supply. It is not suitable for supplying hydraulic oil.

Internal type

► RCD105

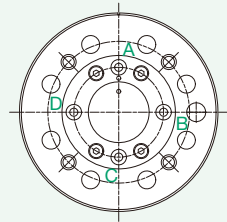
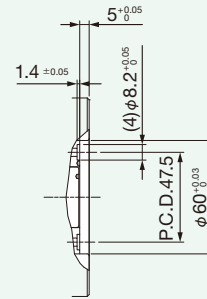
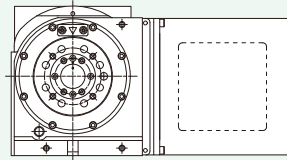
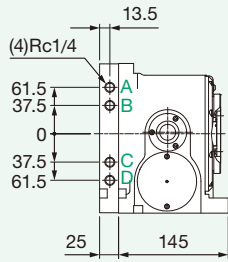

► RCD170,200

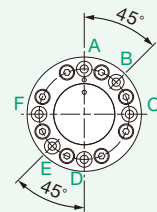
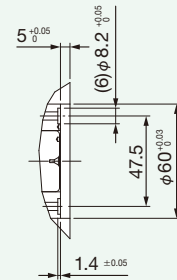
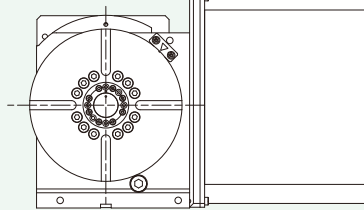
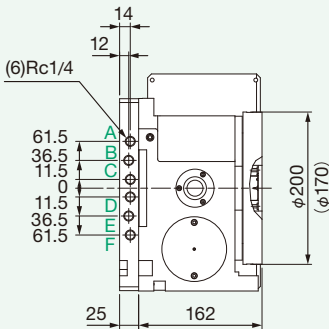

► RCD250,300

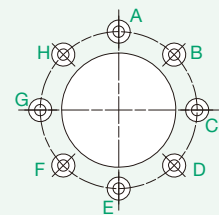
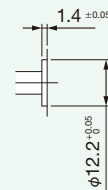
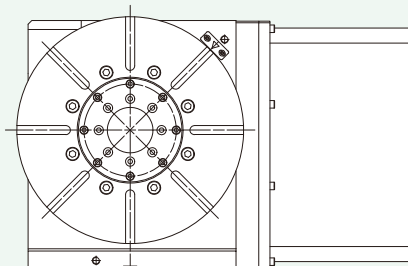
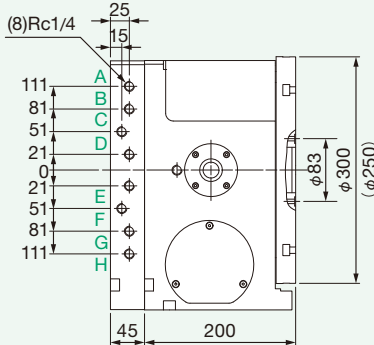

Internal type

▶ RT100

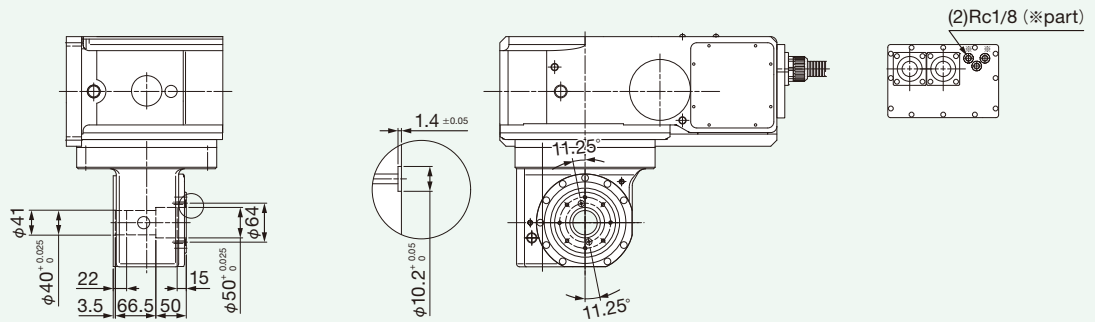

External type

▶ RCD105

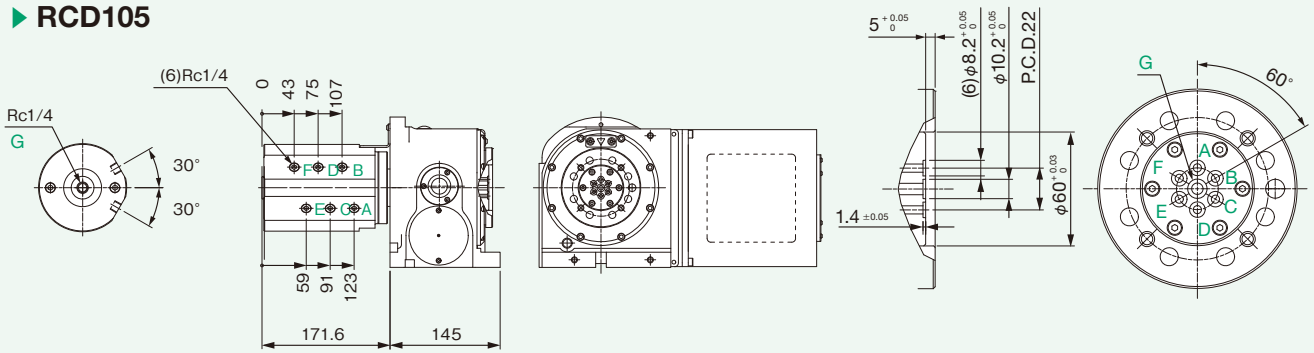

▶ RCD170,200

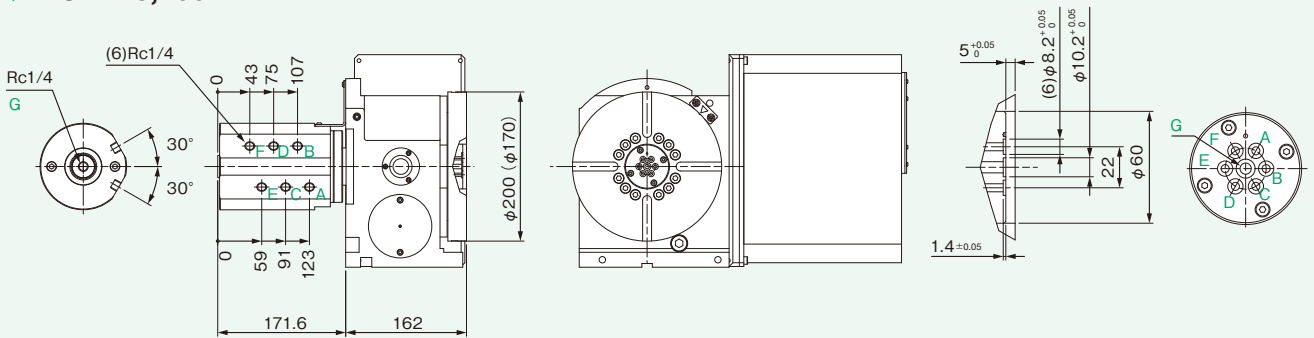

▶ RCD250,300

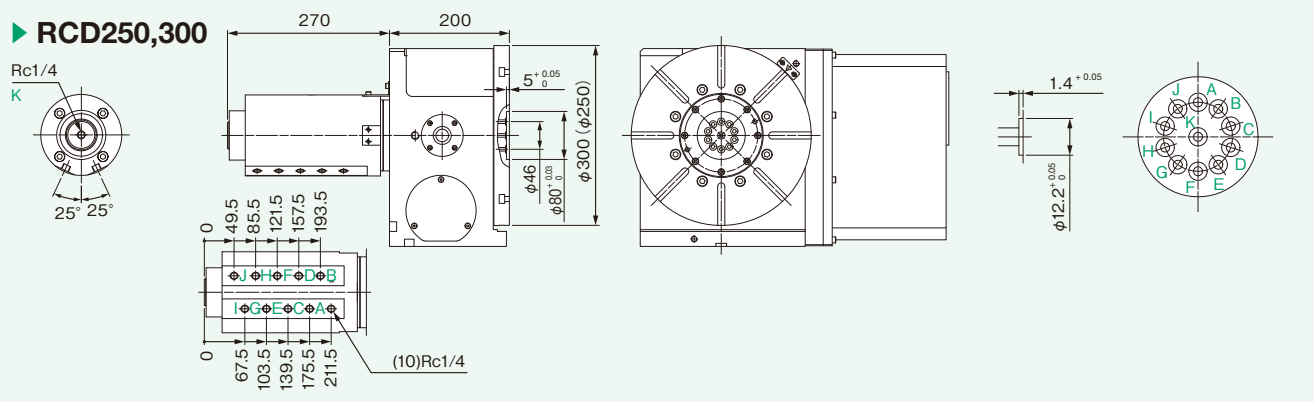

Sizing and Product Code

Specifications / Dimensions

Mount clamps/accessories / Main unit options

Auxiliary equipment

Control methods for air / hydraulic table clamping

Layout dimensions on machine

Precision Ratings

Precautions

Auxiliary equipment — Support table

Specifications

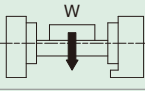
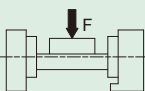
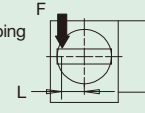
Specifications		ST105A	ST170A		ST250A	
Rotary table model		RCD105	RCD170	RCD200	RCD250	RCD300
Table diameter	mm	Φ105	Φ170		Φ250	
Table pilot bore diameter	mm	Φ60 ^{+0.03} ₀	Φ60 ^{+0.03} ₀		Φ110 ^{+0.035} ₀	
Center height	mm	105	135		185	
Table T slot width	mm	-	12 ^{+0.018} ₀		12 ^{+0.018} ₀	
Keyway width	mm	14. ⁰ _{-0.011}	14. ⁰ _{-0.011}		14. ⁰ _{-0.011}	
Clamp type (air 0.5 MPa, hydraulic 3.5 MPa)		Air / Hydraulic	Air / Hydraulic		Hydraulic	
Clamp torque ¹		N·m	210	310	1200	
Inertia of rotating output part		×10 ⁻³ kg·m ²	0.54	2.10	20.00	
Maximum table speed		min ⁻¹	100	70	60	
Net weight		kg	14	24	54	
Allowable payload ²		kg	100	140	510	
		N	16400	18900	46300	
Allowable load ²		N·m	420	620	2400	
	Continuous holding torque ³	N·m	122	236	416	512
	Maximum holding torque ^{3,4}	N·m	221	362	544	987
	External rotary joint (number of ports)		6+1	6+1		10+1
Internal rotary joint (number of ports)		4	4		6	

*1 Values for ST105A and ST170A are clamping torques when using an air hydro booster with a air pressure of 0.5 MPa as the supply source.

*2 The allowable payload and allowable load values apply to the entire set including the rotary table.

*3 The continuous / maximum holding torque is the allowable load torque when a clamp is not used.

*4 Maximum holding torque should not exceed 10 seconds with 20% duty.



Auxiliary equipment — Support table dimensions

Sizing and Product Code

Specifications / Dimensions

Mount / Main unit options

Auxiliary equipment

Control methods for air / hydraulic table clamping

Layout dimensions on machine

Precision Ratings

Precautions

ST105A

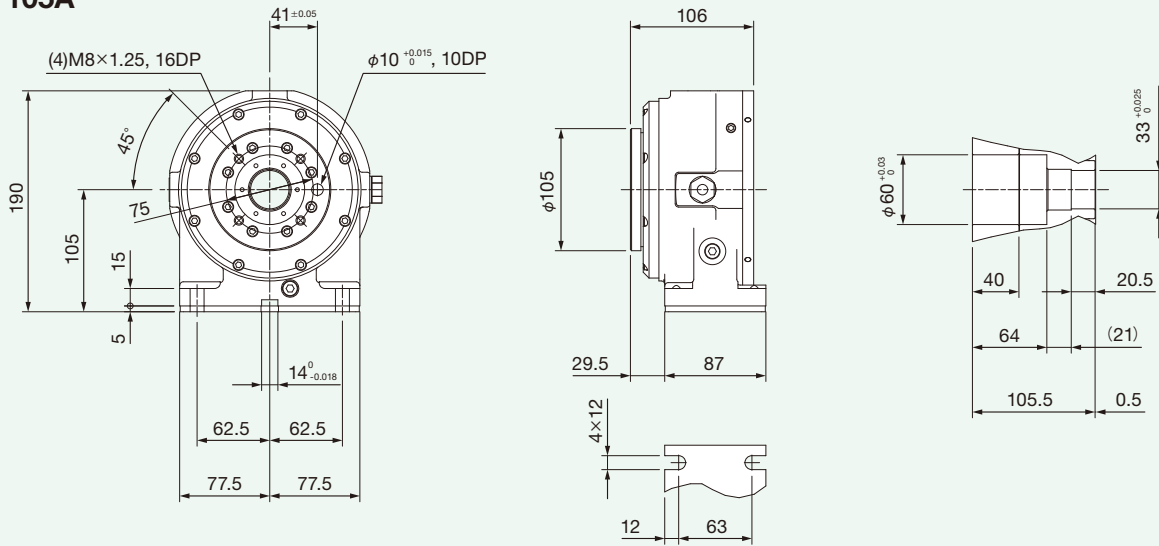

ST170A

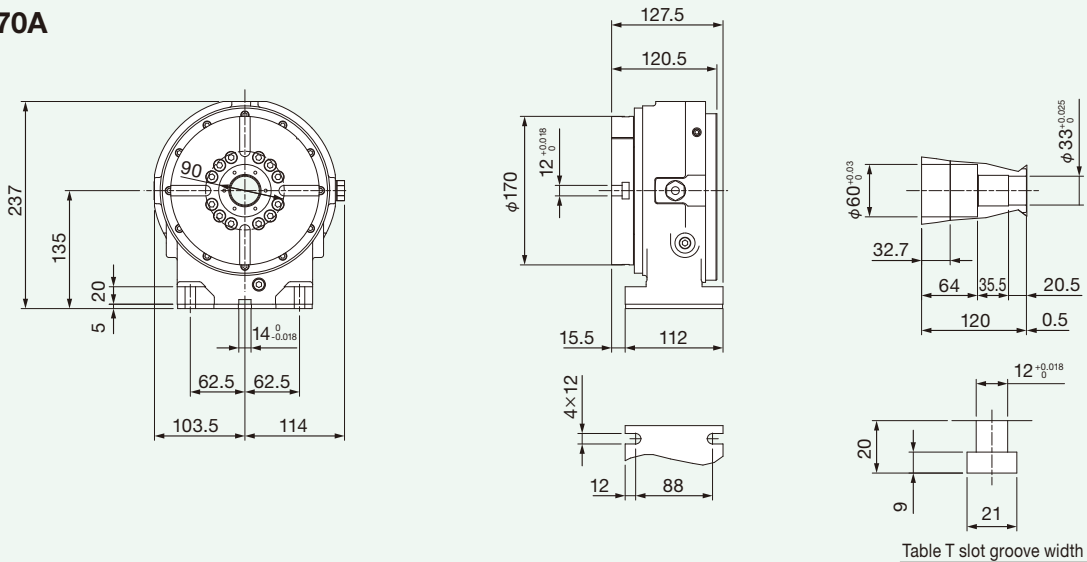

ST250A

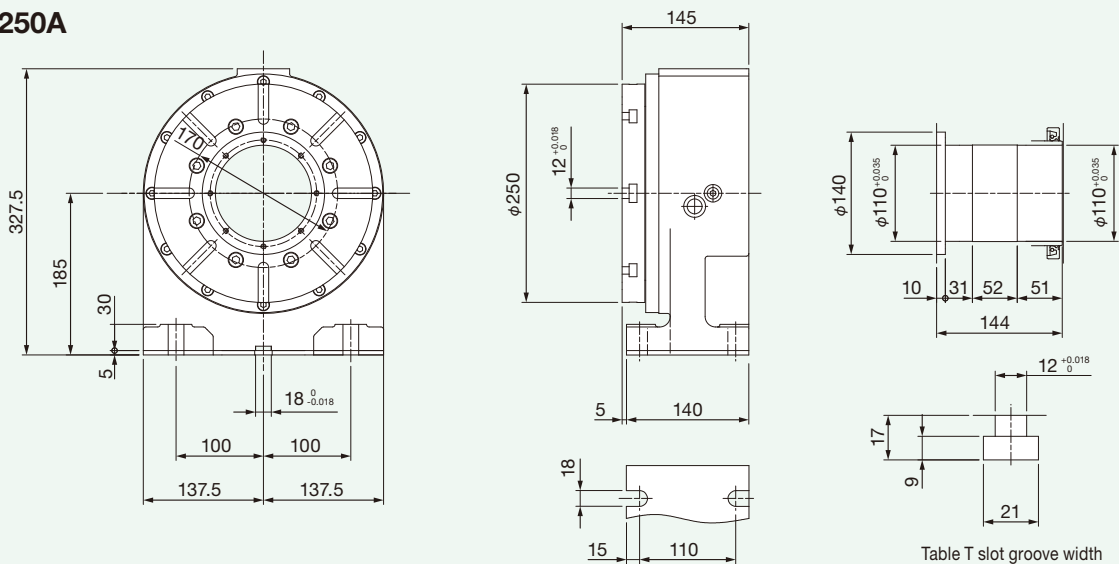

Support table options — Rotary joint

Specifications

Product type	Size	Max. number of ports		Maximum actuation pressure
		Internal type	External type	
ST	105A	4	6+1 ^{*1}	Fluid: Air 0.7 MPa / Hydraulic 6 MPa
	170A	4	6+1 ^{*1}	
	250A	6	10+1 ^{*1}	

*1 The "+1" indicates a port using the center bore.

*2 Be sure to use a line filter in the air supply.

*3 During prolonged use, a small amount of actuation oil may leak from an oil port to an adjacent air port. If possible, the adjacent port should be left open as a drain port.

Internal type

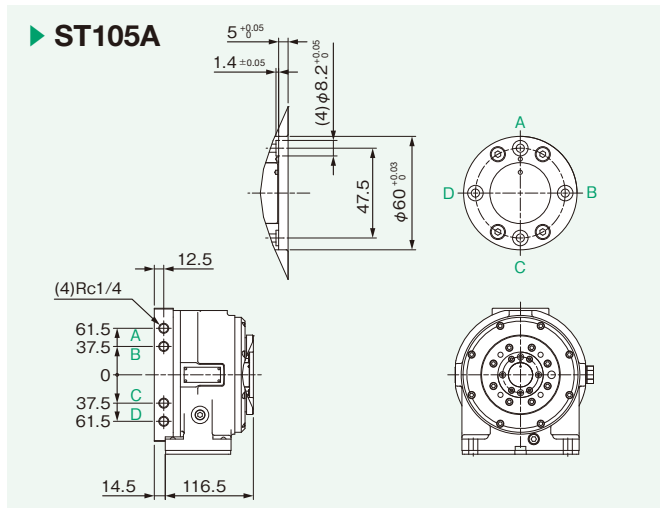

External type

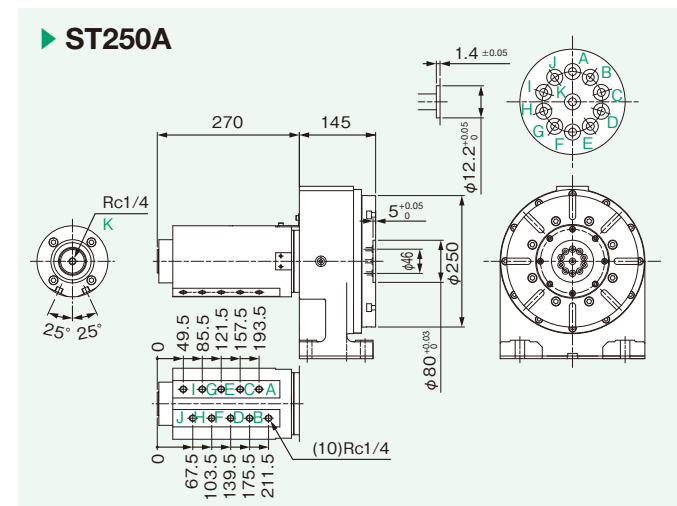
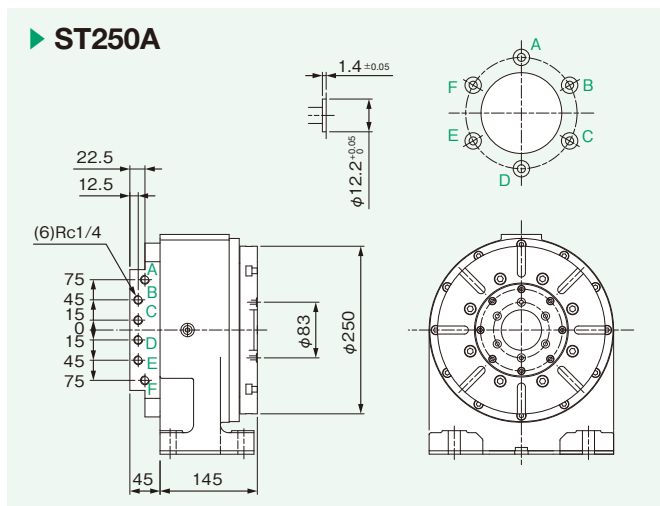
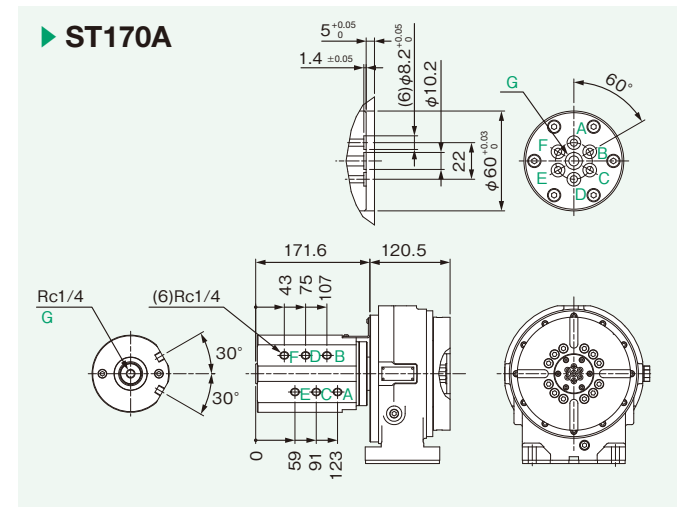
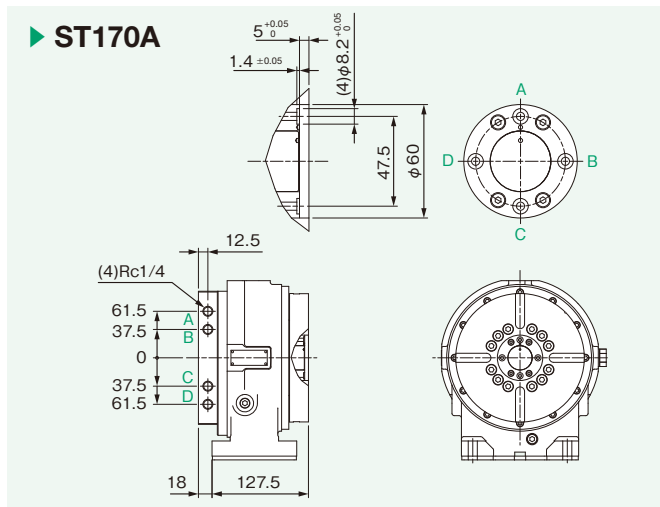
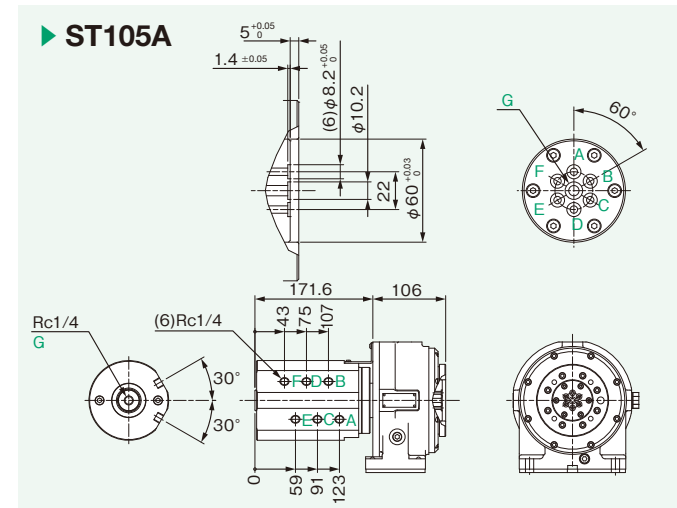



Auxiliary equipment — Tail stock dimensions

Sizing and Product Code

Specifications / Dimensions

Mount clamps/accessories / Main unit options

Auxiliary equipment

Control methods for air / hydraulic table clamping

Layout dimensions on machine

Precision Ratings

Precautions

► TSS105

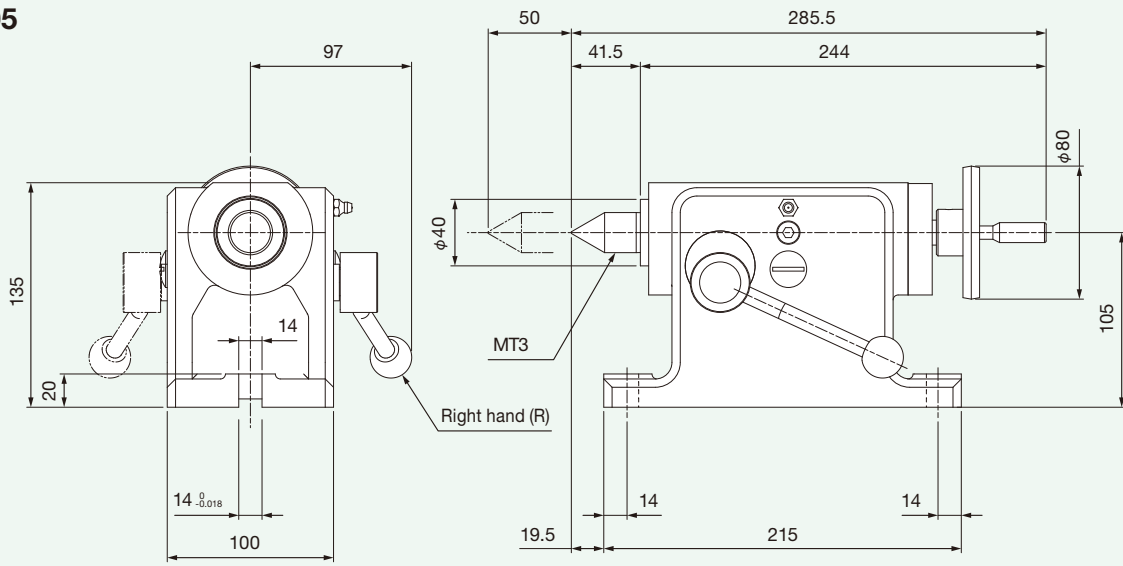

► TSS135

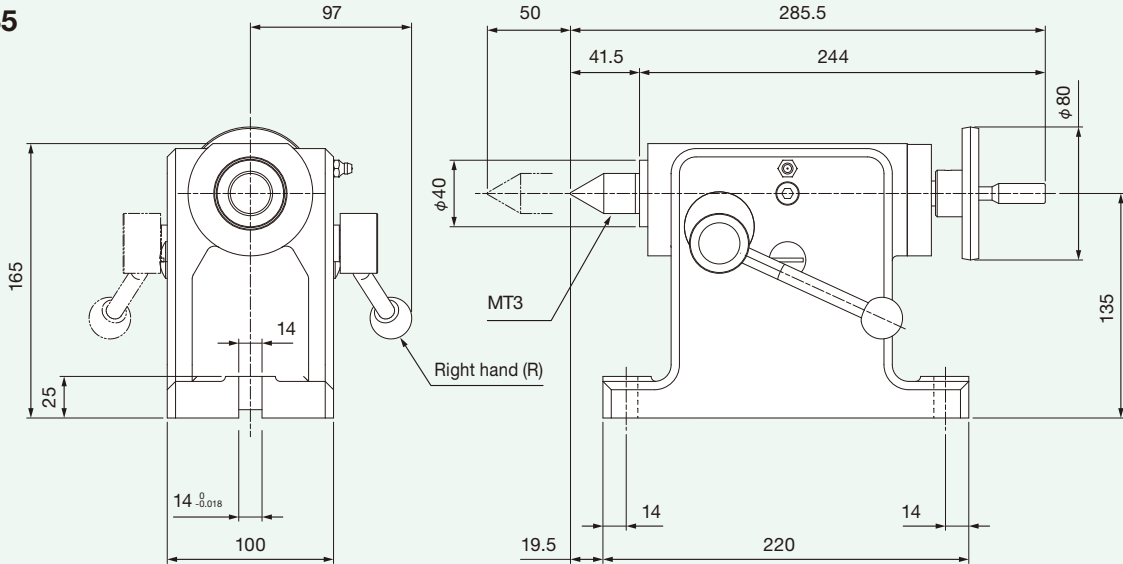

► TSS185

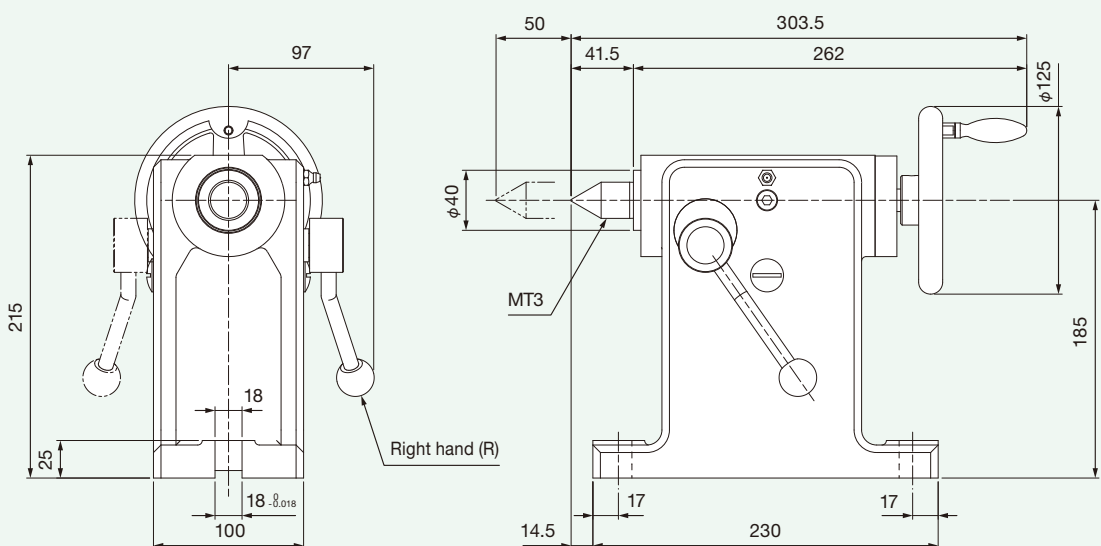

CNC rotary table

Control methods for air / hydraulic table clamping

► Introduction

This section provides information as well as precautions about generally recommended control methods that can be used with Sankyo CNC rotary tables that support air or hydraulic table clamping or motor braking. Because the RollerDrive type CNC rotary tables do not have any structural backlash, clamping is not necessary within certain conditions. This approach eliminates the time required for clamping and unclamping. It allows positioning at maximum speed, while also consuming no energy for a air or hydraulic system.

However, if a very high holding torque to maintain the table at the stop position is required, table clamping can be selected as an optional specification.

* In actual use, the characteristics of the equipment installed by the customer and the functions that are targeted are also relevant. Please use the information provided here as a reference in setting up the appropriate control sequence for the specific application.

► Table clamping

Application	Serves for holding the table at the stop position during machining.
Recommended application	After checking the in-position signal of the drive motor, output the clamp command for the table clamp and check pressure with the pressure sensor. After a specific interval, establish the clamp complete (positioning complete) state.
Using a machine tool servo motor	In principle, servo should be ON, but it is recommended to make provision for servo to be switched OFF if the table clamp was activated while unbalanced torque is generated and the motor current exceeds 70% of the rated value. (The servo motor should be designed for absolute movement and the operation commands must also be issued as absolute values.)
Using a general type servo motor	The following two types of servo motor control are recommended. (1) If servo ON is to be maintained, change proportional integral control to proportional control. This will prevent overload problems. (2) If servo is to be set to OFF, the servo motor's coordinates would be lost if the servo motor is designed for relative movement. To prevent this, an absolute movement type servo motor must be used, and commands must be issued as absolute values.
Points to note	The system is designed for the following operation sequence: Air/Hydraulic pressure ON → Clamp, Air/Hydraulic pressure OFF → Unclamp. Clamping can therefore not be performed when power or the air pressure source will go OFF.

► Motor braking

Application	Serves for holding the table at the stop position during power off or servo off.
Recommended application	Use a servo amplifier or a servo ON/OFF signal from higher-level equipment to turn the motor brake on or off. Braking operation is taken to be completed after a specific interval has elapsed.
Using a machine tool servo motor	The ON timing should be as follows. First use the servo ON signal to enable servo, verify that servo is ON, then release the brake. After a specific interval for brake release has elapsed, the operation is taken to be completed. The OFF timing should be as follows. Use the servo OFF signal to set the brake to ON, and take servo OFF to be completed after a specific interval has elapsed.
Using a general type servo motor	
Points to note	Due to the characteristics of the motor brake function, it cannot be used for holding the table in the stop position during machining or for table control. Otherwise machining accuracy may be affected.

► **Control flowchart** (for type with table clamp, motor brake, and machine tool servo motor)

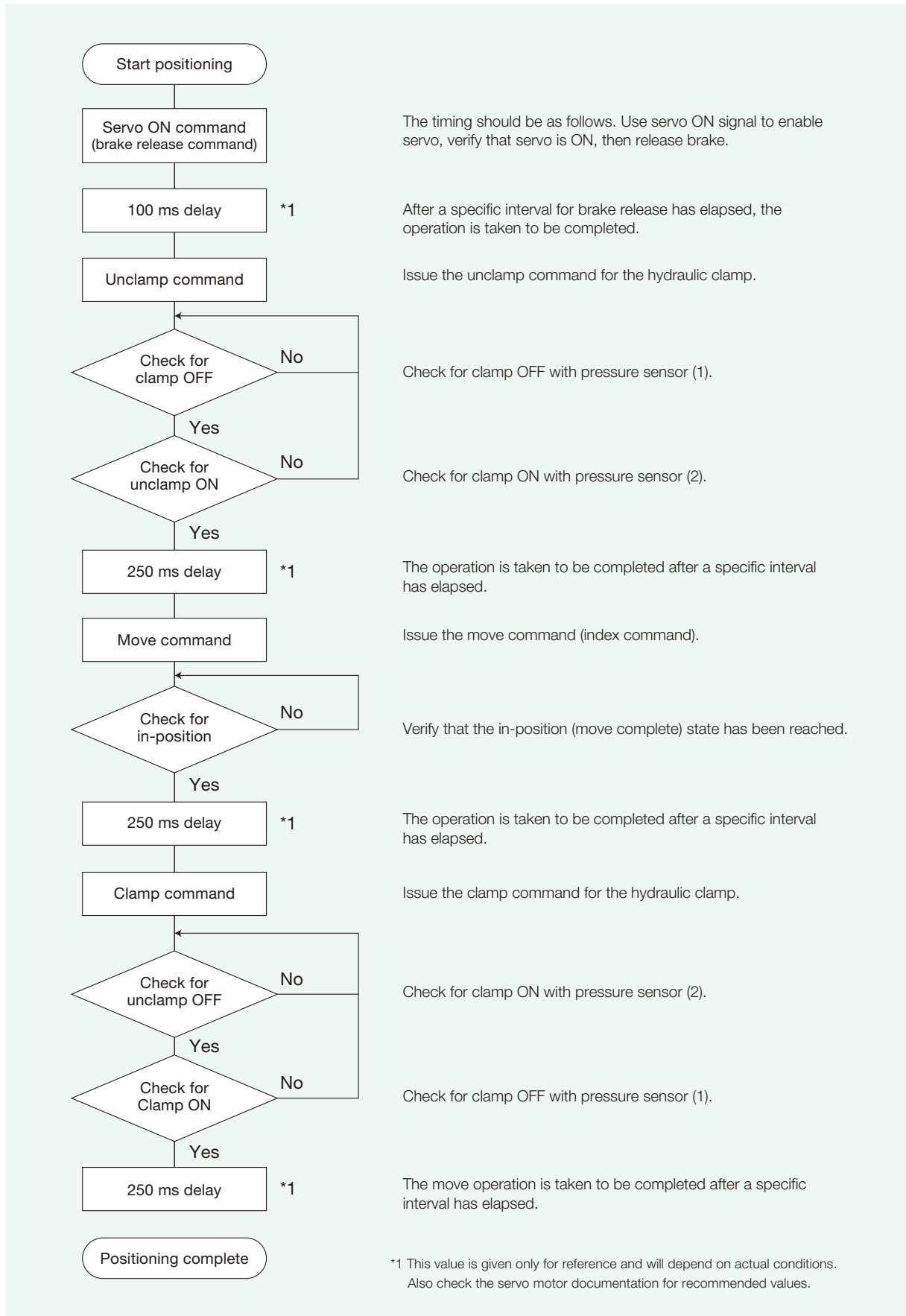



Layout dimensions on machine

α -D21/14SiB [RCD105L]

The drawings apply to the following specifications:
L side motor mounting, rear connector.

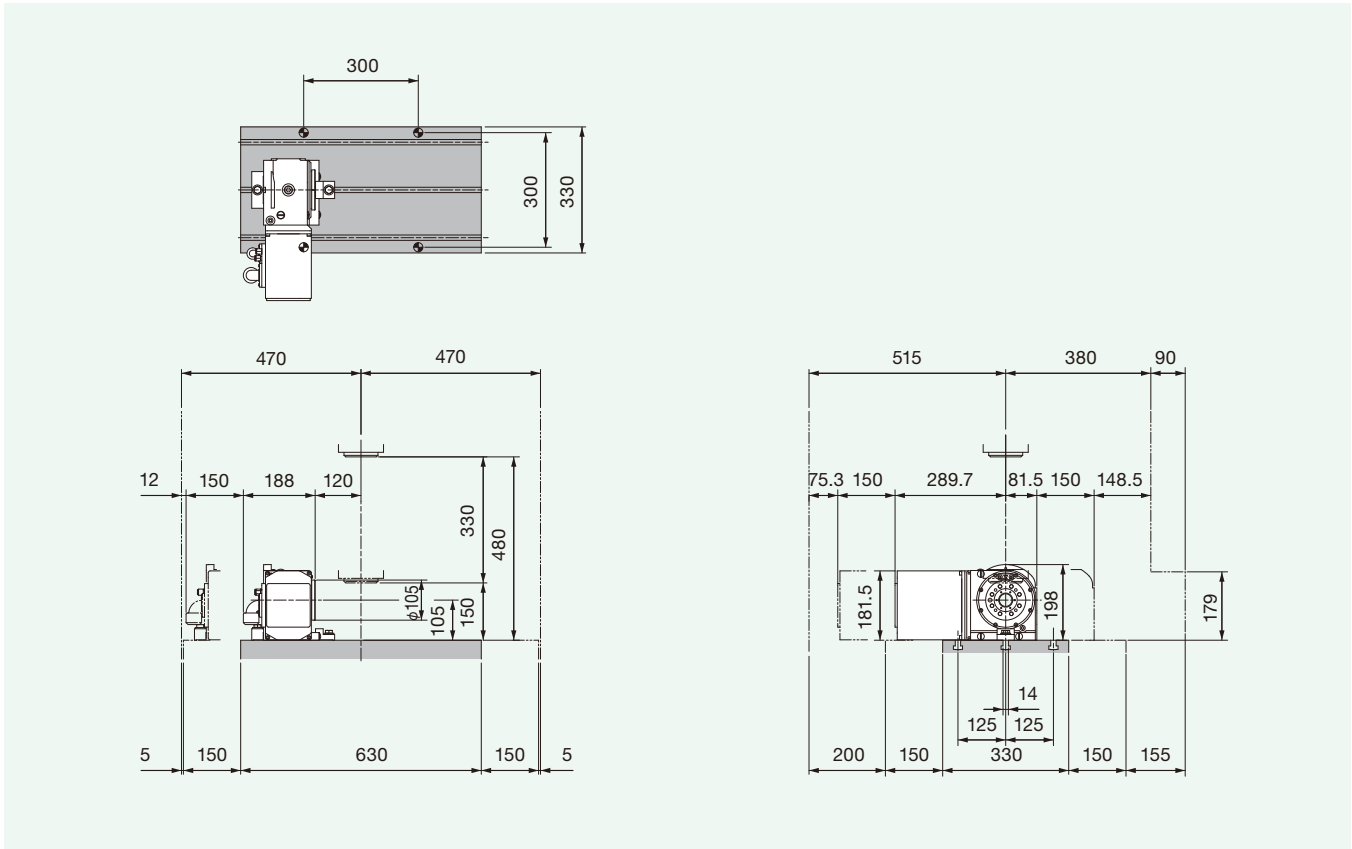

α -D21/14SiB [RCD200L (RCD170L)]

The drawings apply to the following specifications:
L side motor mounting, rear connector.

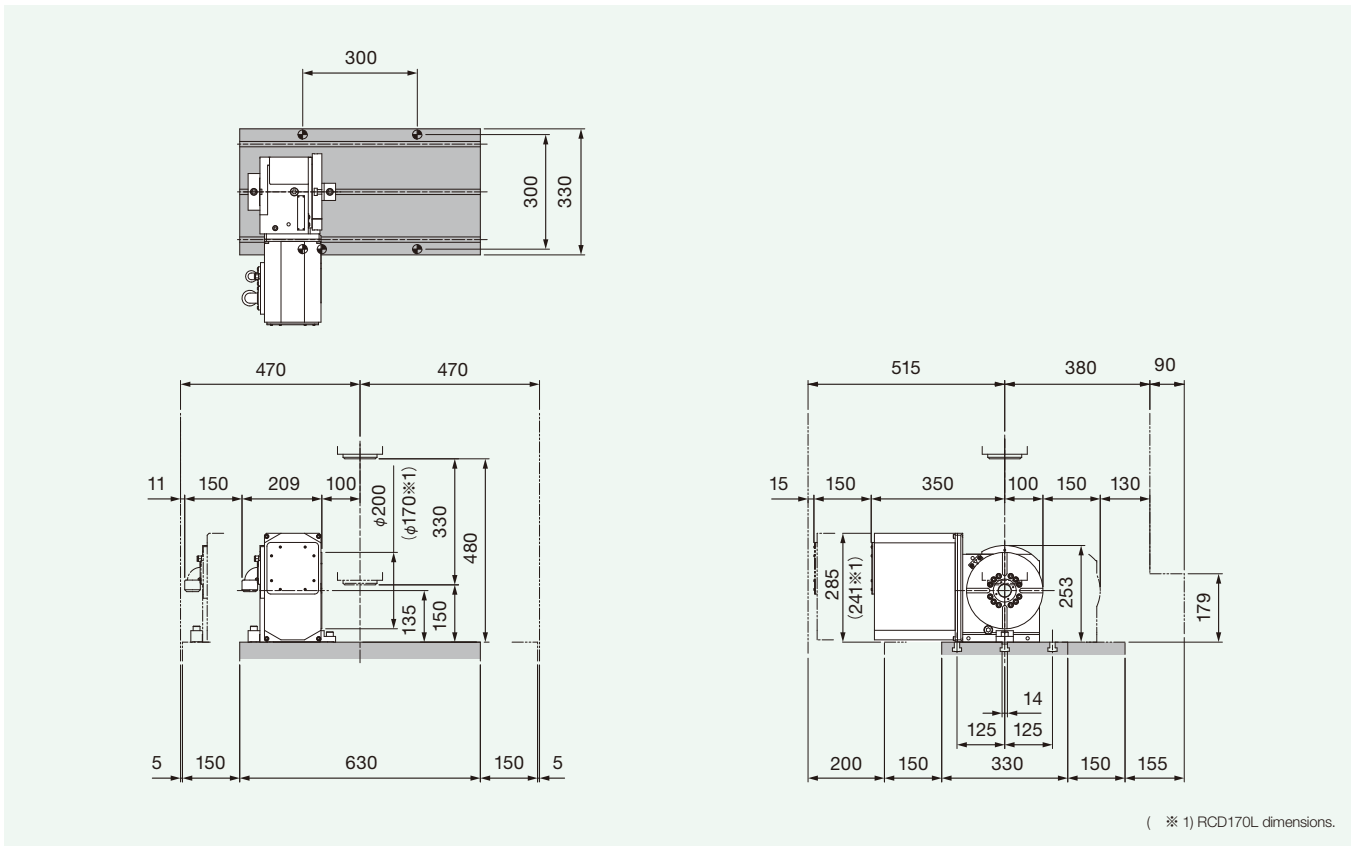

(※ 1) RCD170L dimensions.

α -D21/14MiB [RCD200L (RCD170L)]

The drawings apply to the following specifications:
L side motor mounting, rear connector.

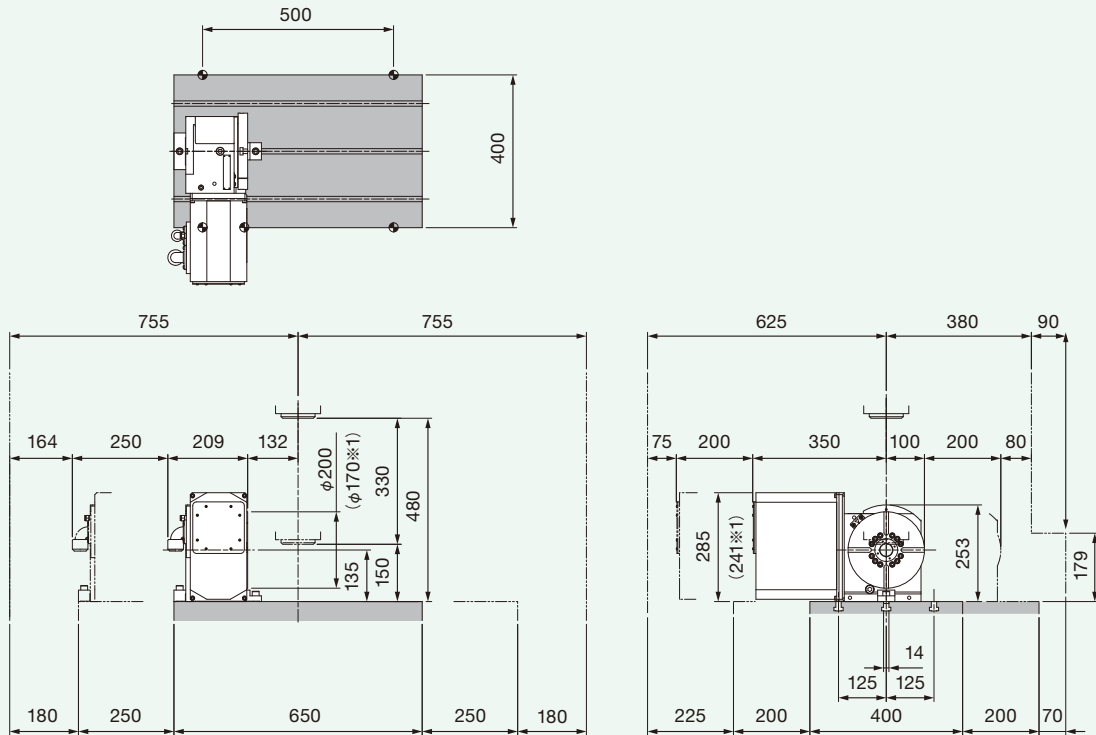

(※ 1) RCD170L dimensions.

α -D21/14MiB [RCD300L (RCD250L)]

The drawings apply to the following specifications:
L side motor mounting, rear connector.

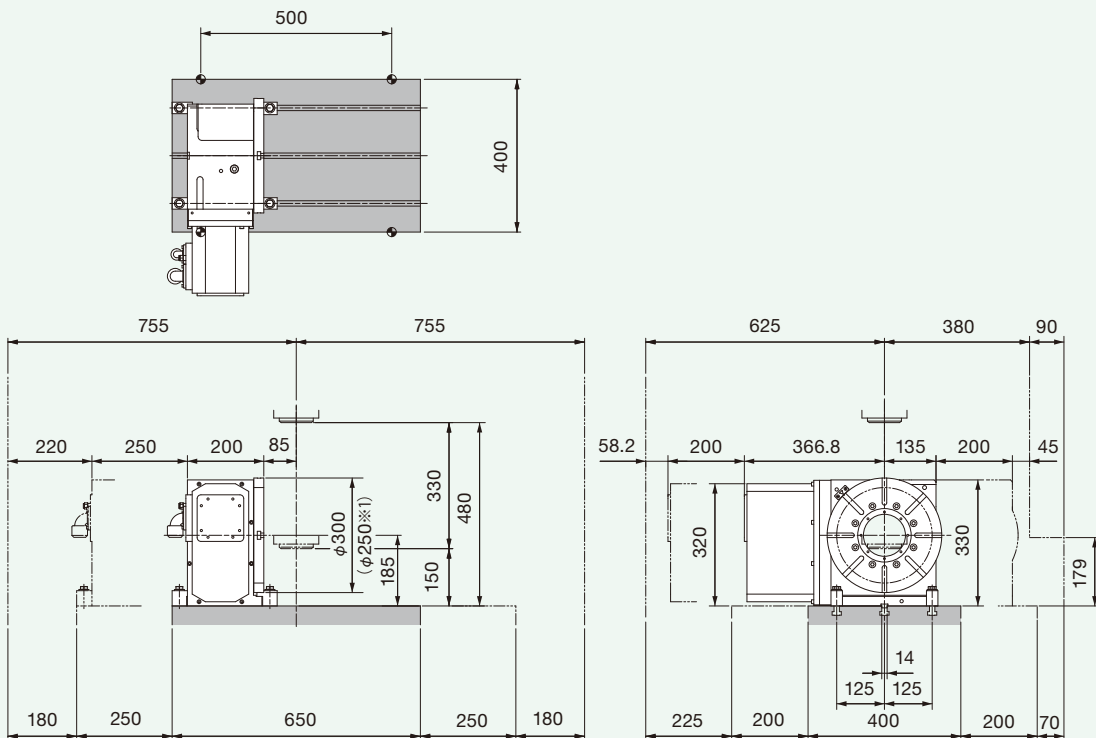

(※ 1) RCD250L dimensions.



Layout dimensions on machine

α -D21/14MiB [RT100R (BC axis)]

The drawings apply to the following specifications:
R side motor mounting, rear connector.

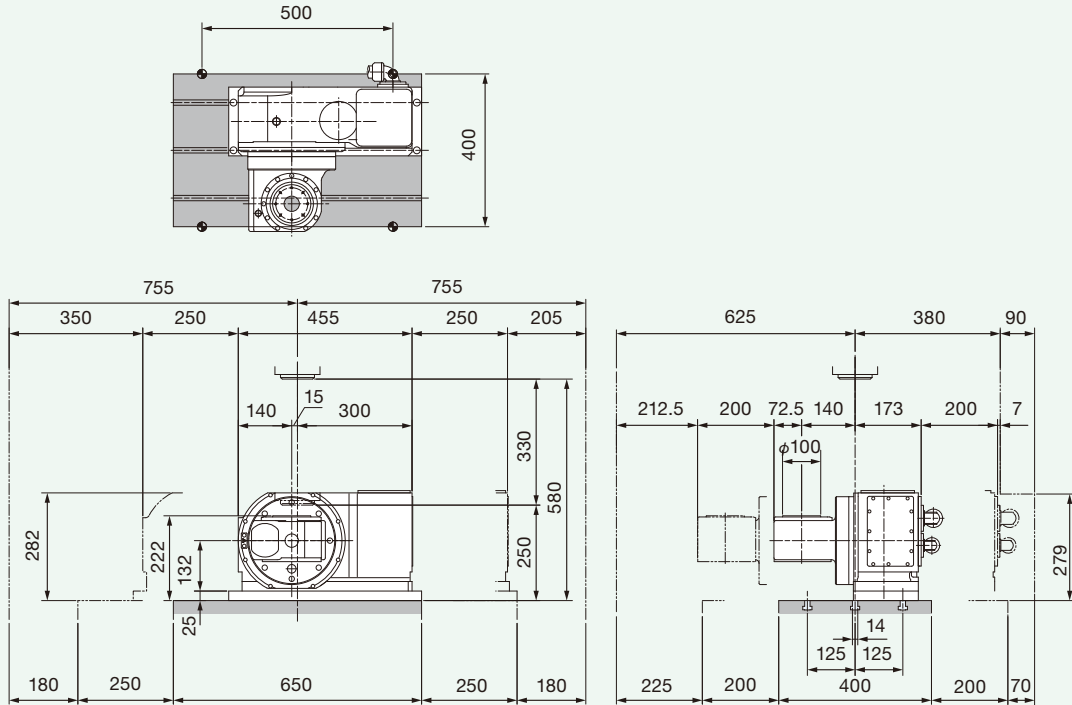

α -D21/14MiB [RT100R (AC axis)]

The drawings apply to the following specifications:
R side motor mounting, rear connector.

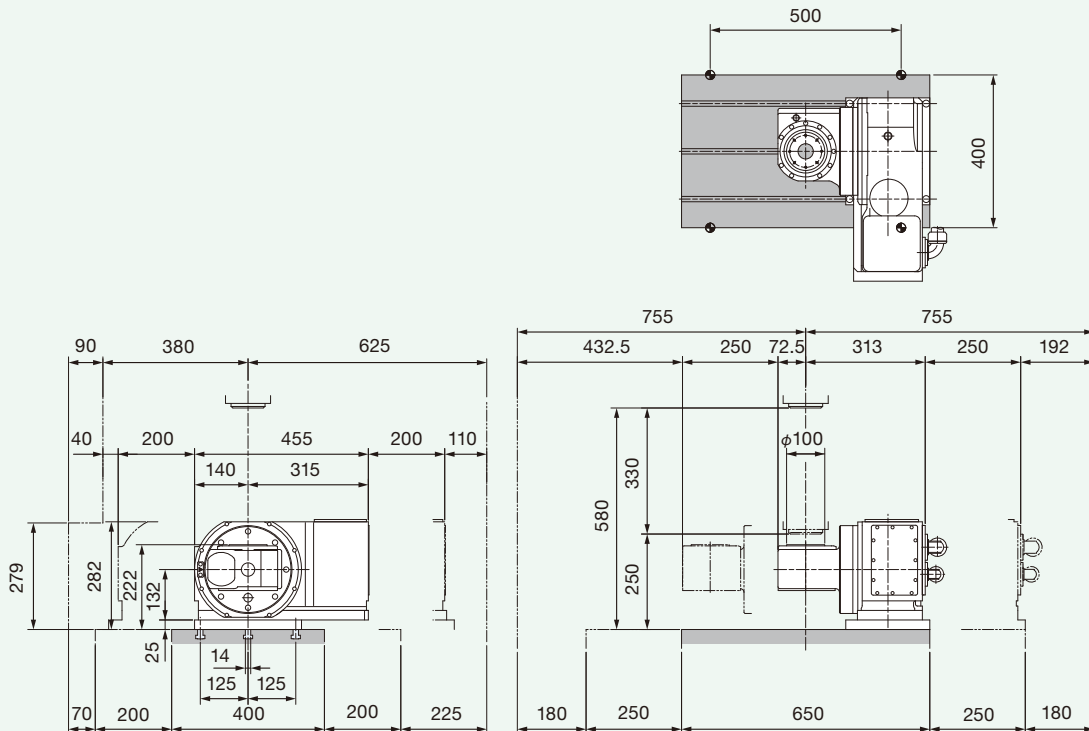

α -D21/14LiB [RCD200L (RCD170L)]

The drawings apply to the following specifications:
L side motor mounting, rear connector.

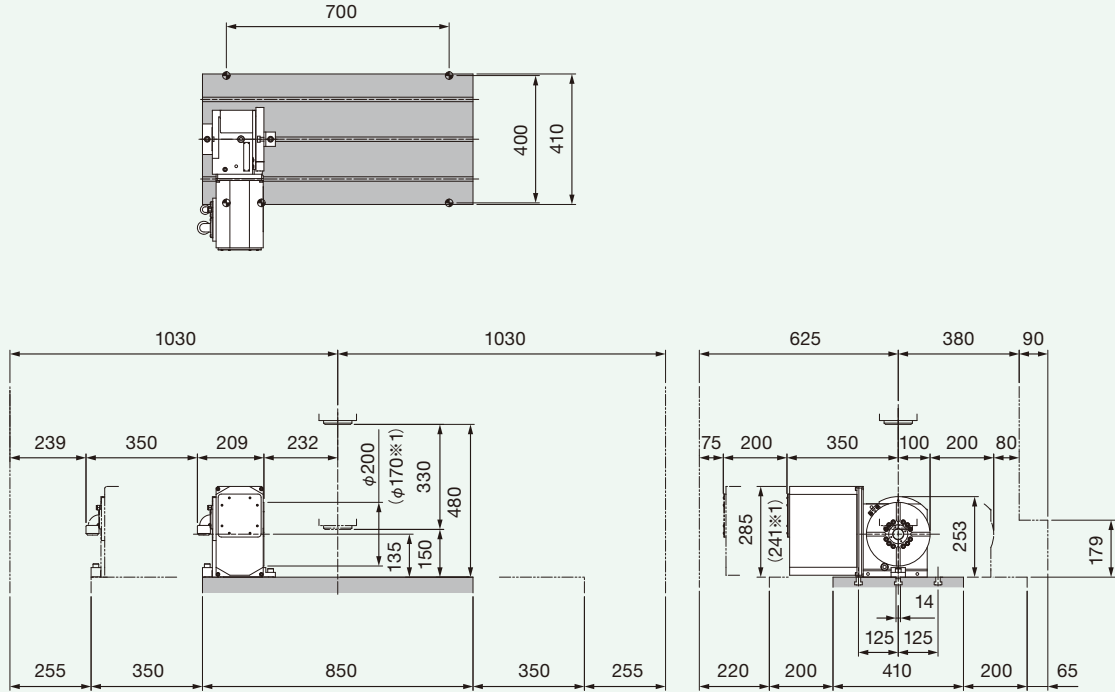

(※ 1) RCD170L dimensions.

α -D21/14LiB [RCD300L (RCD250L)]

The drawings apply to the following specifications:
L side motor mounting, rear connector.

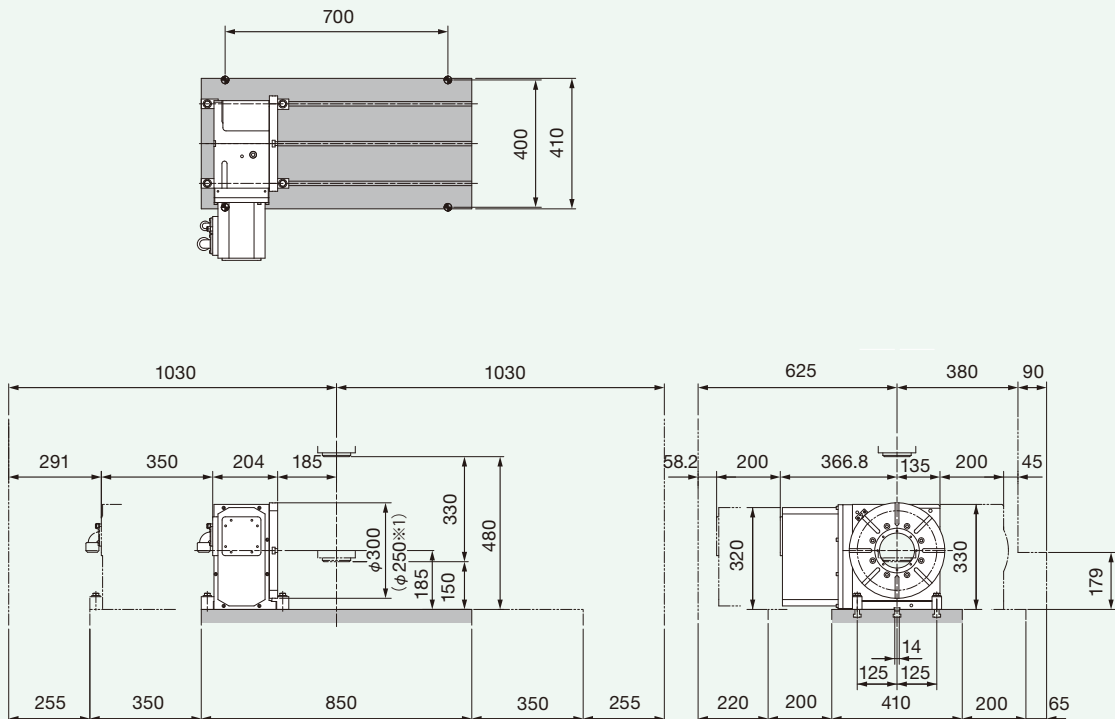

(※ 1) RCD250L dimensions.

Sizing and Product Code

Specifications / Dimensions

Mount clamps/accessories / Main unit options

Auxiliary equipment

Control methods for air / hydraulic table clamping

Layout dimensions on machine

Precision Ratings

Precautions



Layout dimensions on machine

α -D21/14LiB [RT100R (BC axis)]

The drawings apply to the following specifications:
R side motor mounting, rear connector.

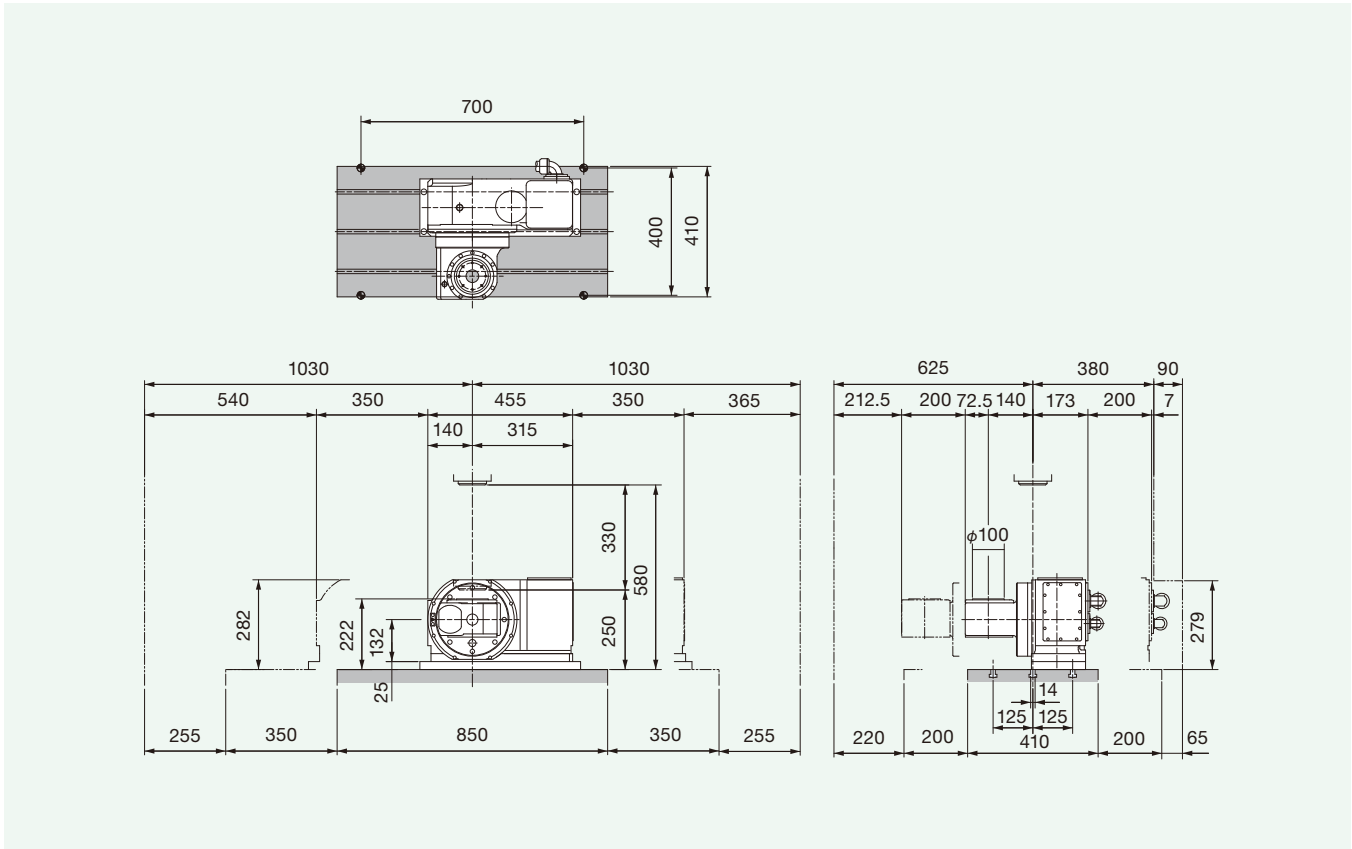

α -D21/14LiB [RT100R (AC axis)]

The drawings apply to the following specifications:
R side motor mounting, rear connector.

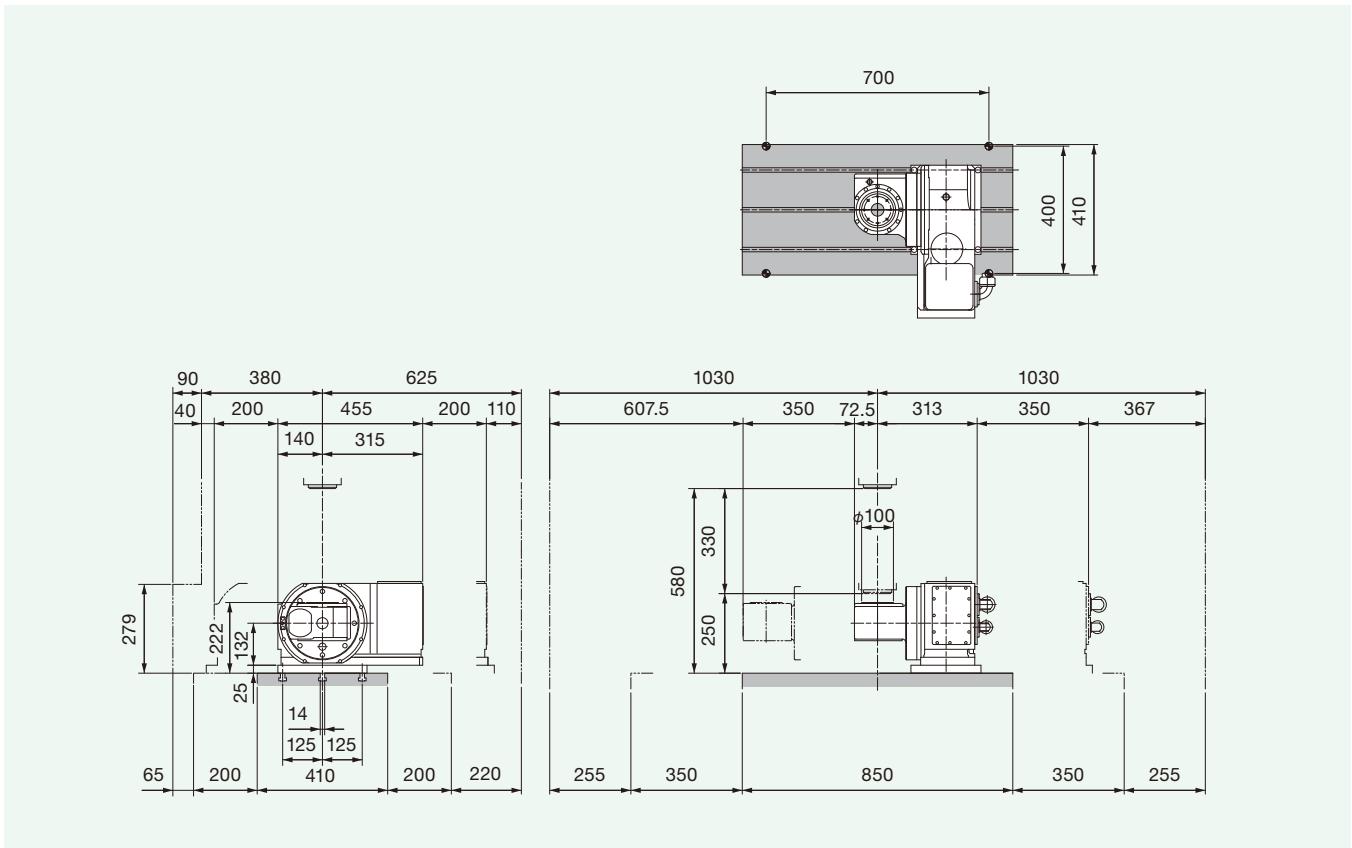

Precision Ratings

1-axis Series

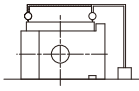
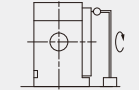
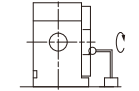
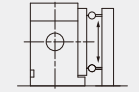
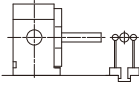
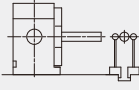
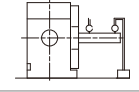
NO.	Measurement	Method	RCD105	RCD170	RCD200	RCD250	RCD300
1	Parallelism between table top and reference surface for upright mounting		0.015mm	0.015mm	0.015mm	0.02mm	0.02mm
2	Runout of table top		0.01mm	0.01mm	0.01mm	0.01mm	0.01mm
3	Runout of table reference bore		0.01mm	0.01mm	0.01mm	0.01mm	0.01mm
4	Perpendicularity between table top and reference surface for upright mounting		0.02mm (must not lean forward)	0.02mm (must not lean forward)	0.02mm (must not lean forward)	0.02mm (must not lean forward)	0.02mm (must not lean forward)
5	Parallelism between rotary axis and guide blocks for reference surface for upright mounting		0.02mm/150mm	0.02mm/150mm	0.02mm/150mm	0.02mm/150mm	0.02mm/150mm
6	Deviation between rotary axis and guide blocks for reference surface for upright mounting		0.02mm	0.02mm	0.02mm	0.02mm	0.02mm
7	Parallelism between rotating center and reference surface for upright mounting		0.02mm/150mm	0.02mm/150mm	0.02mm/150mm	0.02mm/150mm	0.02mm/150mm
8	Indexing accuracy		±15arc.sec	±15arc.sec	±15arc.sec	±10arc.sec	±10arc.sec
9	Repeatability		8arc.sec	8arc.sec	8arc.sec	4arc.sec	4arc.sec

2-axis Series

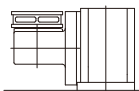
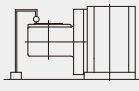
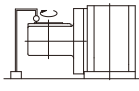
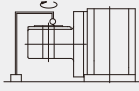
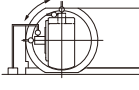
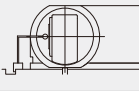
NO.	Measurement	Method	RT100
1	Straightness of table top		0.01mm over full length
2	Parallelism between table top and bottom surface of base		0.01mm
3	Runout of table top		0.01mm
4	Runout of table reference bore		0.01mm
5	Parallelism between tilt axis center line and bottom surface of base		0.02mm over full length
6	Parallelism between table top and guide block		0.02mm
7	Indexing accuracy	Rotary axis	±15arc.sec
		Tilt axis	±10arc.sec
8	Repeatability	Rotary axis	8arc.sec
		Tilt axis	4arc.sec

Sizing and Product Code

Specifications / Dimensions

Mount clamps/accessories / Main unit options

Auxiliary equipment

Control methods for air / hydraulic table clamping

Layout dimensions on machine

Precision Ratings

Precautions

Precautions

▶ Air supply

Sankyo's CNC rotary tables come standard equipped with an air purge outlet. (Use it to blow out condensation and coolant to prolong the life of electrical parts and prevent rust in the motor housing.) Supply clean air for the air purge by referring to the drawing shown. (Do NOT block the exhaust outlet.)

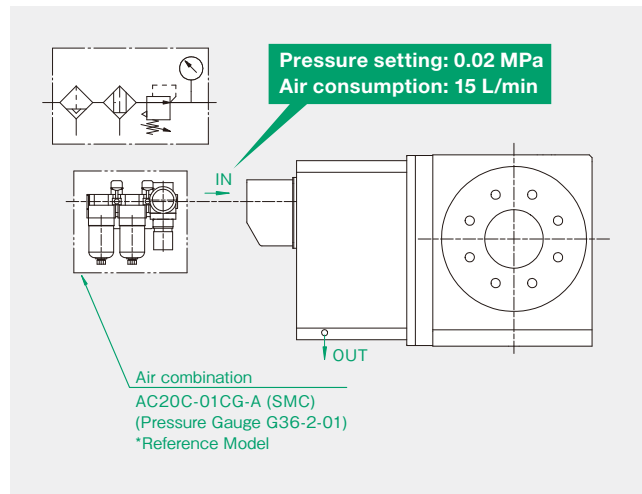

▶ Lubrication

Sankyo's CNC rotary tables use high-performance lubrication oil. Although the lubricant is chemically and thermally stable, it should be changed every 3,000 hours of operation in order to ensure longer product life. Even if operated less than 3,000 hours, the oil should be changed once per year. The condition of the oil can be checked with the oil level gauge while the unit is in the stop condition. Check the oil level and color. If the level is low or the color has changed, change the oil regardless of the number of operation hours. Some air bubbles may form in the oil during operation. This is normal and does not affect quality.

* Be sure to use only the lubricant specified below. Otherwise service life may be reduced and parts may deteriorate.

Specified lubricant: Mobil SHC629 (VG150)

▶ Use in grinding machines

When used in grinding machines, the seal device on the outer periphery of the table may become damaged. The warranty does not cover such damage.

▶ Maximum rotation speed

The maximum rotation speed for the table given in the specifications refers to the indexing speed. Consult with Sankyo if the table is to be rotated continuously. Otherwise, the table will heat up and lose accuracy, causing overload alarms with the servo motor.

▶ General Precautions

- Under the Japanese trade regulation, RollerDrive CNC can be restricted to supply or export to a country which may produce weapons or related products.
- Dimensions and specifications are subjected to be modified without notice.
- Contents of this catalogue is published in March 2021.
- Whole or part of the contents, mechanisms, logos, drawings belongs to Sankyo-Seisakusho, Japan. No part of the catalogue is allowed to copy or redistributed to the third party without the permission of Sankyo Seisakusho.

Global network

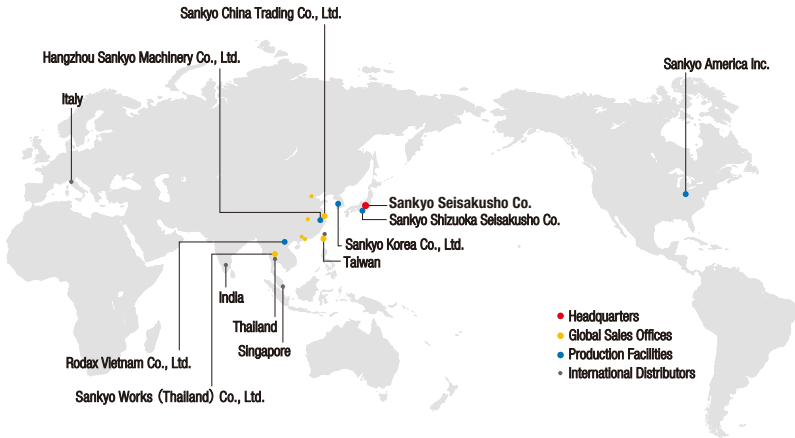

Group Companies

Sankyo America Inc.

10655 State Route 47 Sidney, Ohio, 45365 U.S.A.
 Phone: +1-(0)937-498-4901 Fax: +1-(0)937-498-9403
 Email: sales@sankyoautomation.com

Sankyo Korea Co., Ltd.

1449-48 Seobu-ro, Gwonseon-gu, Suwon-si, Gyeonggi-do, 16643 Korea
 Phone: +82-(0)31-895-5991 Fax: +82-(0)31-895-6607
 Email: kr-sales@rollerdrive.com

Sankyo China Trading Co., Ltd.

[Shanghai Sales Office]
 Room 1103, Block B, No.391 Guiping Road,
 Shanghai 200233 China
 Phone: +86-(0)21-5445-2813 Fax: +86-(0)21-5445-2340
 Email: sales@sankyochna-trading.com

[Shenzhen Sales Office]

Unit 19J, Tower B, NEO Building, No.6009 Shennan Avenue,
 Futian District, Shenzhen China
 Phone: +86-(0)755-8230-0270 Fax: +86-(0)755-8236-4605

[Tianjin Sales Office]

Room 1905, Pengzhanfeiwu Building A, Crossing Yale Road Yaolin Road,
 Xiqing District, Tianjin 300380 China
 Phone: +86-(0)22-2312-1005 Fax: +86-(0)22-2312-1007

[Guangzhou Sales Office]

Room 913, Xing Pu building, No.12 Guan Hong Road,
 Guangzhou Economic Development Zone, Huang Pu, Guang Zhou 510670 China
 Phone: +86-(0)20-8985-1846 Fax: +86-(0)20-8225-7346

[Wuhan Sales Office]

Room 2301, Taihe Square, No.134 Wusheng Road, Wuhan,
 Hubei Province China
 Phone: +86-(0)27-8568-5818 Fax: +86-(0)27-8568-2818

Hangzhou Sankyo Machinery Co., Ltd.

No.2518 Jiang Dong 2 Road, Hangzhou Jiang Dong Industrial Park,
 Xiaoshan Zone, Hangzhou, Zhejiang, China
 Phone: +86-(0)571-8283-3311 Fax: +86-(0)571-8283-1133

Rodax Vietnam Co., Ltd.

Plot No. M1, Thang Long Industrial Park II
 Di Su, My Hao, Hung Yen, Viet Nam
 Phone: +84-(0)221-3-589701 Fax: +84-(0)221-3-589708

Sankyo Works (Thailand) Co., Ltd.

9/31 Moo 5, Phaholyotin Road, Klongnueng,
 Klong Luang, Patumthani 12120 Thailand
 Phone: +66-(0)2-516-5355 Fax: +66-(0)2-068-0931
 Email: sales@sankyo-works.co.th

Contact us

Mon-Fri AM8:30-12:00 PM13:00-17:30 UTC + 09:00 (JST) (Except public holidays and company holidays)

■ **Headquarters**
(International Sales Division) 3-37-3 Tabatashinmachi, Kita-ku, Tokyo, Japan 114-8538
 Phone: +81-(0)3-3800-3330
 Fax: +81-(0)3-3800-3380
 Email: overseas@sankyo-seisakusho.co.jp
 URL: <http://www.sankyo-seisakusho.co.jp>

■ **Taiwan Sales Office** No.21, Ln.152, Jianxing Rd., Sanhe Vil., Daya Dist., Taichung City 42876, Taiwan (R.O.C.)
 Phone: +886-(0)4-2359-4048
 Fax: +886-(0)4-2359-4720
 Email: tw-sales@rollerdrive.com

Sizing and Product Code

Specifications / Dimensions

Mount clamps/accessories / Main unit options

Auxiliary equipment

Control methods for air / hydraulic table clamping

Layout dimensions on machine

Precision Ratings

Precautions



<http://www.sankyo-seisakusho.co.jp>

- * Photos of the Robodrill are used courtesy of Fanuc Corporation.
Sankyo Seisakusho is responsible for the manufacture of the CNC Rotary Table and CNC Tilting Table.
- * All patent rights and copyrights for parts of mechanisms described in this catalog and for trademarks, images, drawings etc. belong to Sankyo Seisakusho Co.
"RollerDrive" is a registered trademark of Sankyo Seisakusho Co. in Japan.

