



SANKYO
SEISAKUSHO CO.

LinerUnit

CS series

Received the 26th Award for Excellence in The Best New Technology and Products Award for Small and Medium Enterprises.

Long Stroke Linear Drive Unit

LinerUnit

CS series

Japanese patent number 4538212
Japanese patent number 4700944

For Long Stroke Applications
High-speed, High-power, New-Technology Linear Unit

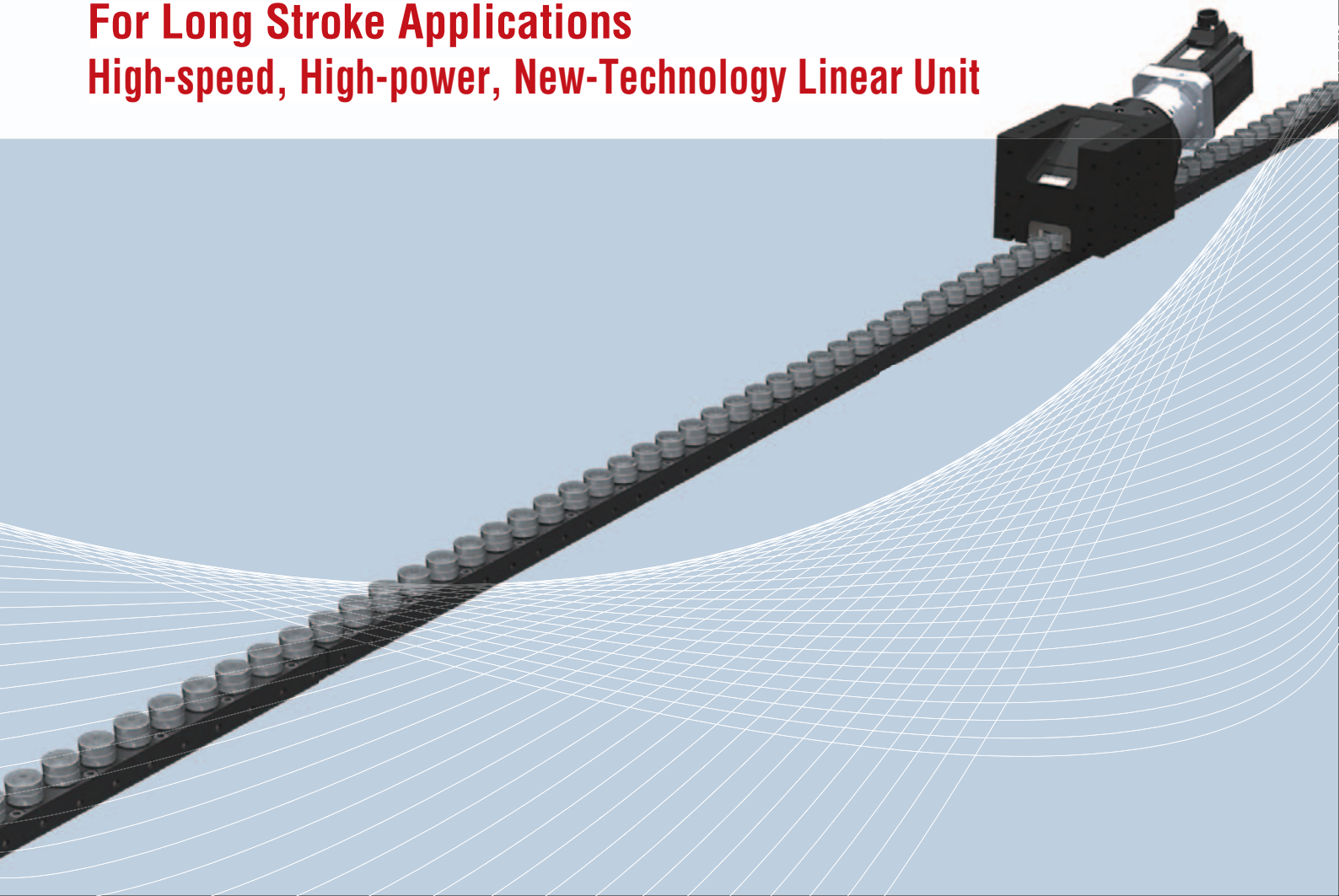

Next-Generation Linear Positioning Liner Unit Realizing High Speed & High Power

Robot Conveyance

High-power, High-speed, High-serviceability and High-accuracy Linear Drive Positioning Unit Aiming for the Highest Performance

The Liner Unit is a high-speed, high-power, linear drive unit based on an adaptation of the cam mechanism. Powered by a servomotor, and featuring a new mechanism that rotates a screw-shaped cam, the Liner Unit travels along a linear rail, enabling high-speed, long-distance conveyance of heavy loads impossible with conventional mechanisms. This enables conveyance of heavy materials, large multifunction robots and other production equipment. This exciting next-generation linear conveying unit will lead to advanced automation of production lines and improved productivity.

Features

1. Long stroke

The integrated drive and rail-guided motion unit solves the "rope jumping" effect caused by deflection in ball screws, and overcomes obstacles created by supports that are commonly used between rails to prevent deflection. Simply connect the rails for long stroke applications of 10 meters or longer (length is theoretically unlimited).

2. High-speed

Suitable for high-speed motions of 200 m/min or more for drastically reduced moving times. The screw rotates perpendicular to the direction of travel, and has excellent acceleration and deceleration characteristics as well as small residual vibration during sudden stops, reducing system cycle times.

3. High-power

A motor size of 0.75 kW can move a heavy 300-kg load over 4 meters in only 3.5 seconds.

4. Excellent durability

Drive power is transmitted by rolling contact for minimal wear and prolonged initial accuracy. Retains initial repeatability of $\pm 4 \mu\text{m}$ with virtually no loss even after 10,000 km of travel. (Repeatability measured after 10,000 km: $\pm 5 \mu\text{m}$)

5. Maintenance

In case of accidents such as unit collisions, the affected bearing or unit can be replaced separately, allowing quick and easy recovery of the entire system.

6. Multi-axis control

Two or more Liner Units can be installed and controlled separately on a single axis, allowing users to create diverse types of motion by combining linear and rotary movements.

7. Small footprint

Inline drive and rail design uses 50% less space than other mechanisms.

Linear positioning unit performance comparison

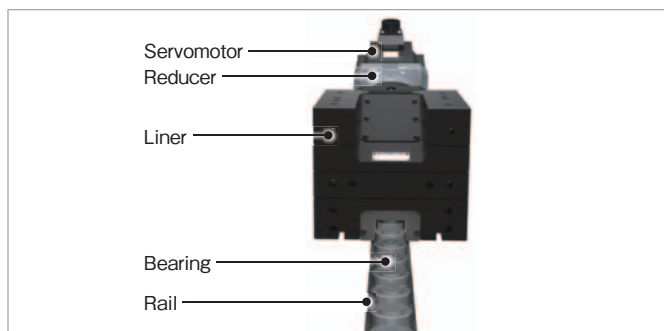
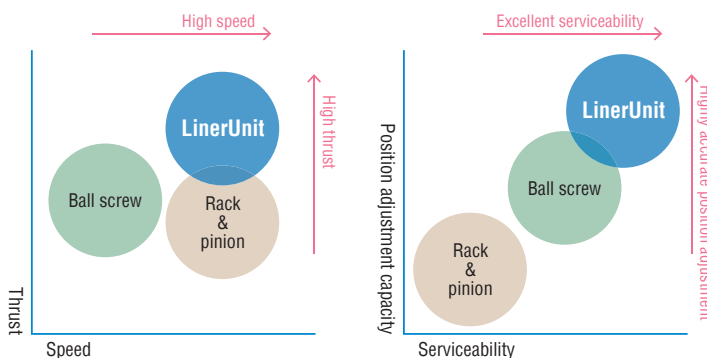

Moving times by payload (CS30)

Payload	Moving time		
	1m	2m	4m
100kg	1.0sec	2.0sec	3.5sec
200kg	1.3sec	2.0sec	3.5sec
300kg	1.5sec	2.3sec	3.5sec

* See specifications for the loading capacity.

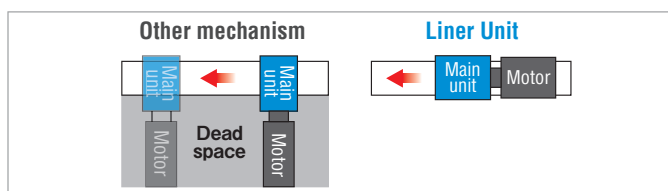

Applications

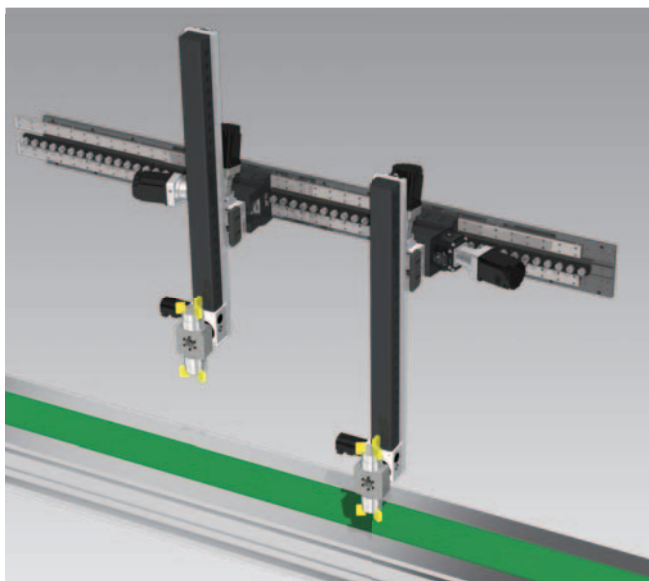

Gantry loader

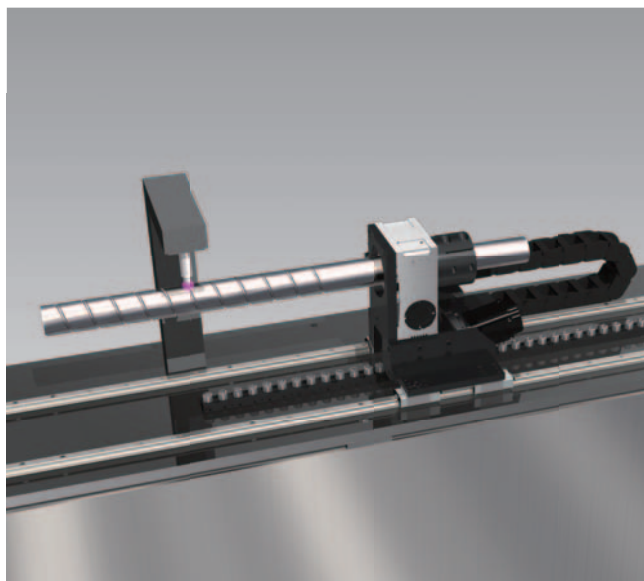

X-θ positioner (laser processing machine)

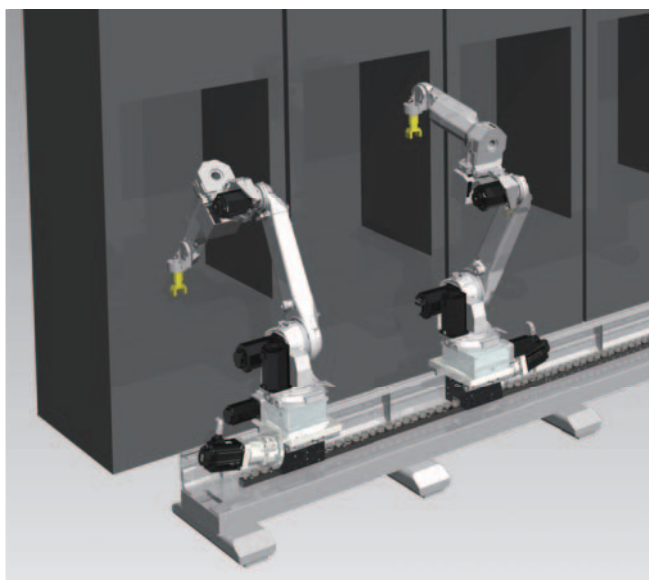

Workpiece conveyance between machining centers

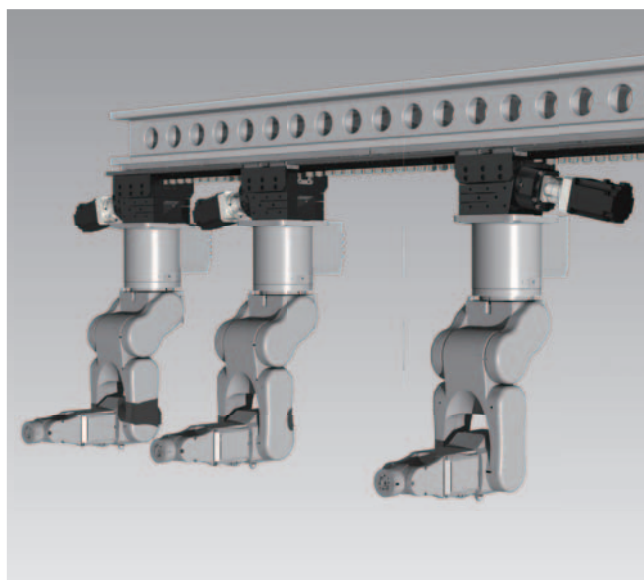

Suspended robot conveyance

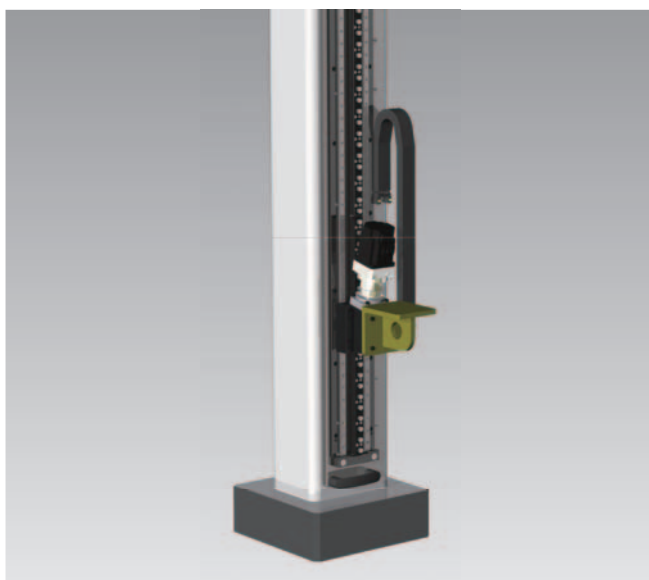

Lifting apparatus

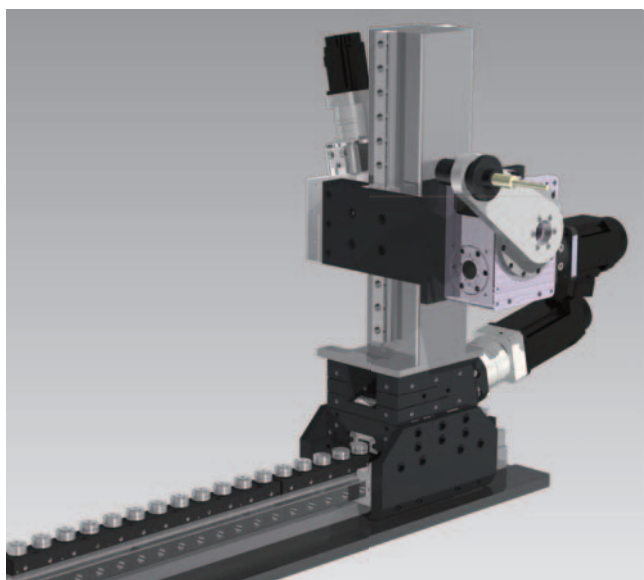

XY-θ positioner

Product Code

Liner

¹ CS	² 16	³ C
------------------------	------------------------	-----------------------

1	2	3	
Model	Sizes	Specifications	
CS	10	C	Component Specification* ¹
	16		
	22		
	30		
	40		

- *1 Linear Guide is required for Component Specification. Please procure it by the customer.
- *2 The reducer is not included in this cord. Please place in order separately.
- *3 The dimension of the reducer may differ by using servo motor and the reduction ratio.
- *4 CS10 and CS16 cannot be shipped without mounting on the reducer.
If you procure the reducer by your company, please provide it. We will ship with mounted on the Liner.
- *5 Please procure the servo motor by the customer.
- *6 The backlash of the reducer which we select Nidec-Shimpo Manufacture VRB series is three minutes.

Rail

¹ CR	² 16	³ C	-	⁴ T1	⁵ S
------------------------	------------------------	-----------------------	---	------------------------	-----------------------

1	2	3	
Model	Sizes	Specifications	
CR	10	C	Component Specification
	16		
	22		
	30		
	40		

4		5	
Bearing Specifications		Rail Specifications	
T1	Standard	S	Steel* ²
		A	Aluminum* ^{1,2}

- *1 Aluminum rail is only for the Component Specification of CS10, CS16, CS22, and CS30.
- *2 Steel surface treatment is black oxide and aluminum surface treatment is anodized black.
- *3 This code is one rail.
- *4 If you need to order more than one, please calculate the strokes and place an order. (refer the calculation formula of the number for rails P.8)
- *5 The rail connection is required the exclusive connection bracket. Please order separately.

Product Code

Option (Service Parts)

¹ CP	² 16	-	³ CB
-----------------	-----------------	---	-----------------

1	2	3	
Model	Sizes	Specifications	
CP	10	CB	Rail Connection Bracket* ¹
	16	LS	Lub Sheet (Maintenance Parts)
	22	T1	Guide shaft for rail and Bearing (Maintenance Parts)* ²
	30		
	40		

*1 Rail Connection Bracket is required for the connection of the rail.

*2 This code is the set of one guide shaft and bearing for the rail.
One set of this parts is as follows.

	Guide Shaft	Collars	Bearing
CS10	1	1	2
CS16	1	1	3
CS22	1	1	2
CS30	1	1	2
CS40	1	1	2

*3 The number of the guide shaft and the bearing set that required by 1 rail are as follows.

	Number used per 1 rail
CS10	22
CS16	20
CS22	14
CS30	12
CS40	14

Specifications

Item	Units	CS10	CS16	CS22	CS30	CS40	
Lead	mm	90	50	70	90	110	
Transmission accuracy (*1)	μm	30/300mm					
Repeatability (*1)	μm	± 20 (± 10 : without reducer)					
Allowable loading capacity	N	200	500	750	1000	5000	
Screw's moment of inertia	$\text{X}10^{-4} \text{kg}\cdot\text{m}^2$	1.5	3	8	64	162.1	
Mass	Liner	kg	1.5	3	7	15	30
	Rail (Steel)		0.8 (L=490)	1.5 (L=495)	2.5 (L=485)	5 (L=535)	13 (L=765)
	Rail (Aluminum)		0.4 (L=490)	0.9 (L=495)	1.2 (L=485)	2.6 (L=535)	—
	Reducer		0.6	1.4	1.4	3.7	8
Standard rail length	mm	490	495	485	535	765	
Surface treatment	Liner	Anodized black					
	Rail	Steel/black oxide		Aluminum/anodized black			
Lubrication oil		Mobilgear 600 XP 320					

*1 Accuracy readings are based on internal test bench results (20°C)

*2 Excluding mass of servomotor.

Dimension Drawings: Component Specification

CS10

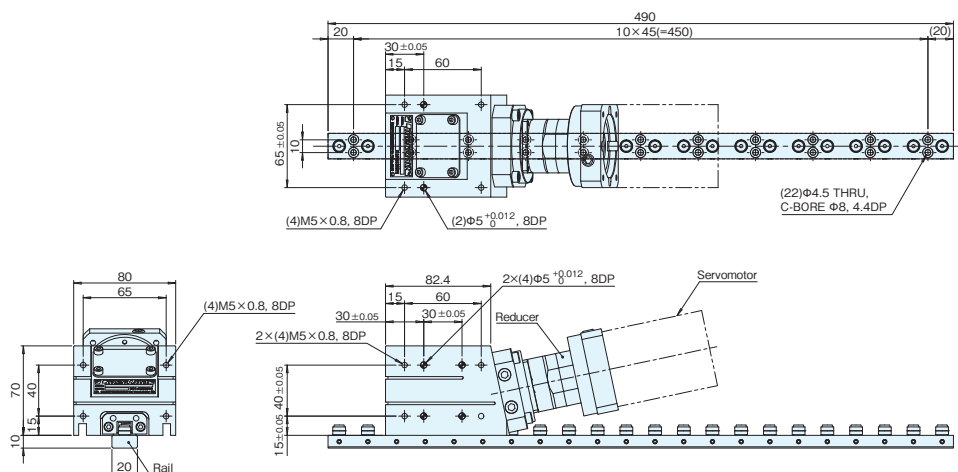

* Usable stroke of only one rail is 395 mm. *2 Please procure a servomotor and linear guide.

CS16

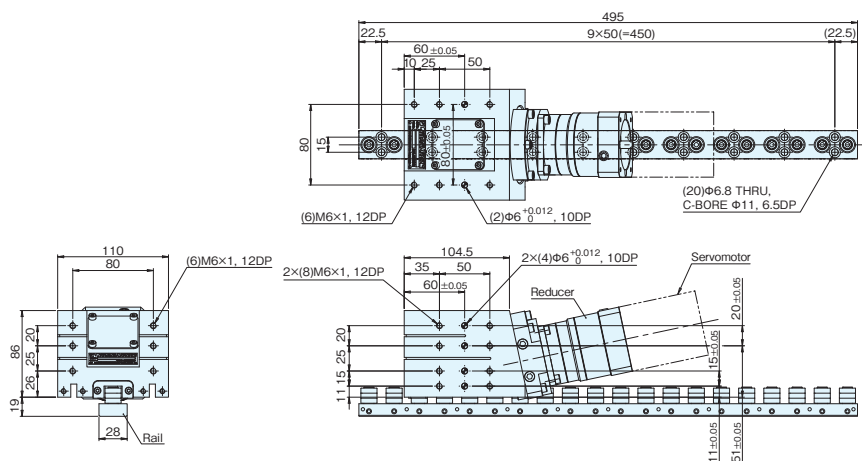

* Usable stroke of only one rail is 375 mm. *2 Please procure a servomotor and linear guide.

Dimension Drawings: Component Specification

CS22

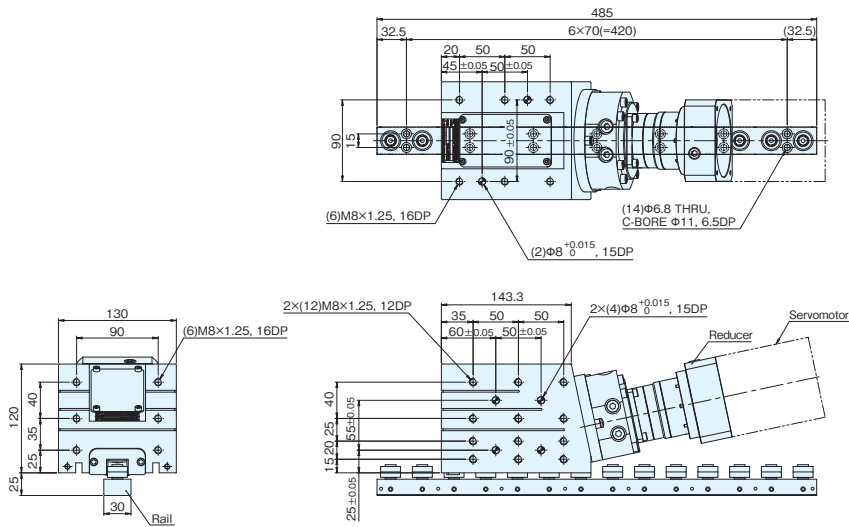

* Usable stroke of only one rail is 355 mm. *2 Please procure a servomotor and linear guide.

CS30

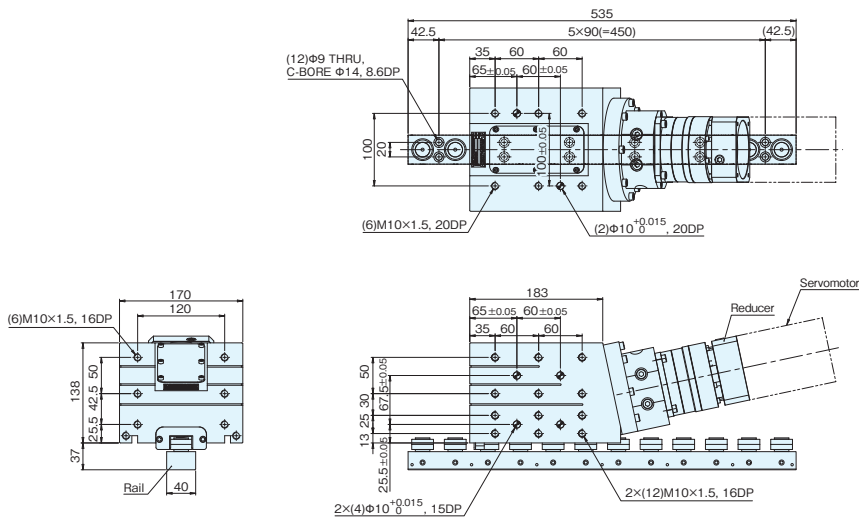

* Usable stroke of only one rail is 355 mm. *2 Please procure a servomotor and linear guide.

CS40

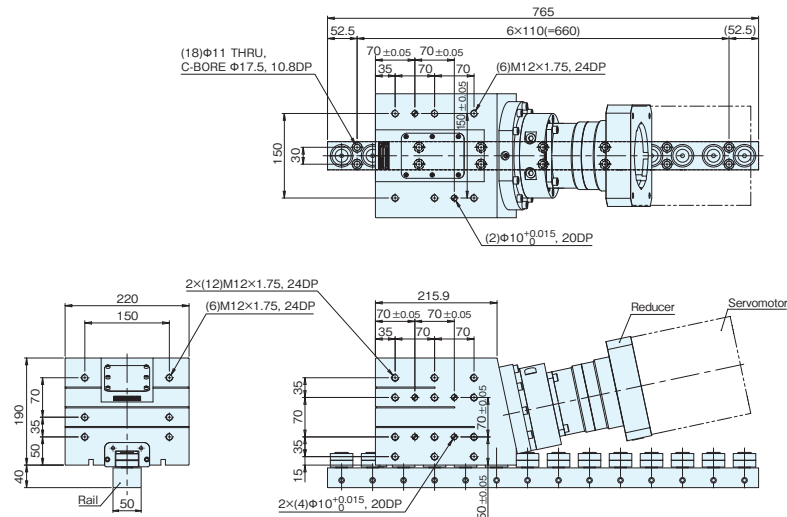

* Usable stroke of only one rail is 550 mm. *2 Please procure a servomotor and linear guide.

Dimension Drawings: Reducer Installation Area

CS10

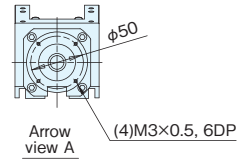
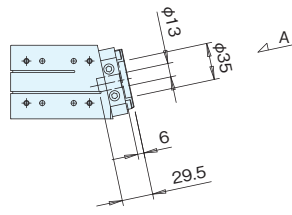

CS16

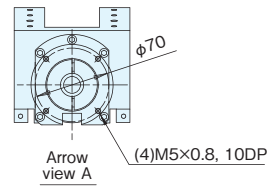
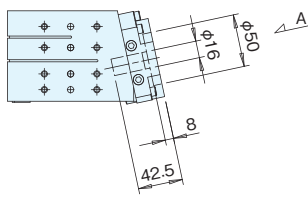

CS22

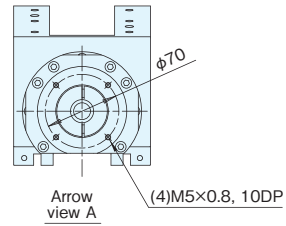
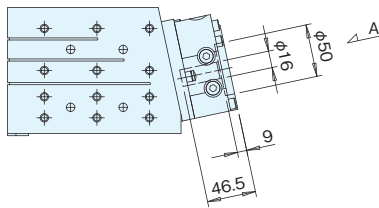

CS30

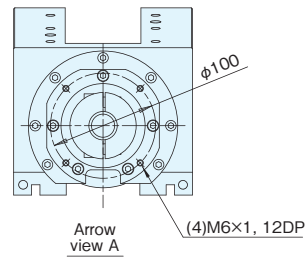
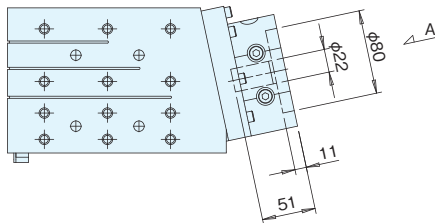

CS40

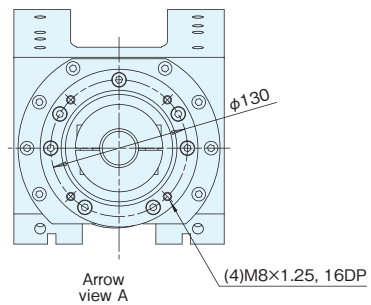
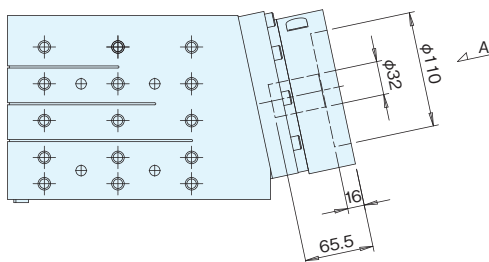

How to Connect Rails

The LinerUnit can be used for long-stroke applications by connecting rails.

Use separately sold rail connection bracket to adjust the bearing pitch of the connection area.

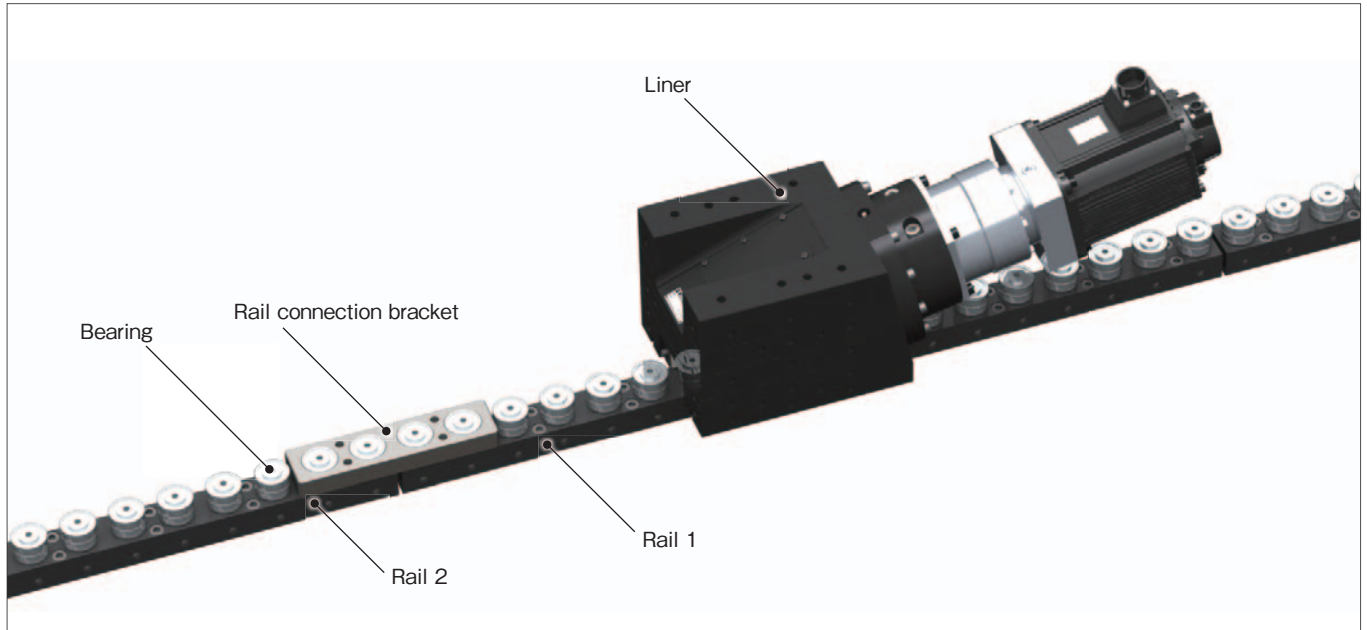

Stroke Capable Range, Number of Rails required for Formulas

Component Specification

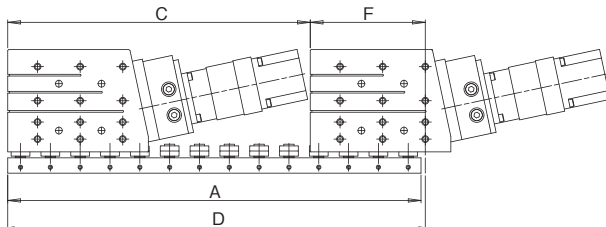

Unit:mm

	CS10	CS16	CS22	CS30	CS40
Rail Length A	490	495	485	535	765
One Rail Stroke Effective Length C	395	375	355	355	550
Stroke Increased Amount at the Connection D (A+5mm)	495	500	490	540	770
Stroke Ineffective length F	100	125	135	185	220

<Formulas for Finding Number of Rails>

$$X = (L - C) / D + 1$$

*Round up the nearest integer.

Conditions

- Number of rails X
- Stroke L(mm)

Calculation of thrust

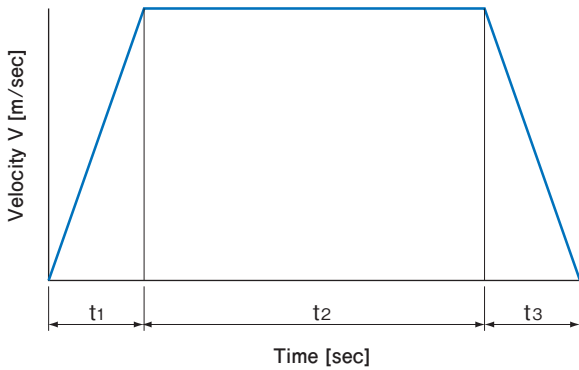

Calculations

① Speed V (m/sec)

$$V = \frac{l}{\frac{(t_1+t_3)}{2} + t_2} \text{ (m/sec)}$$

② Acceleration A (m/sec²)

$$A = \frac{V}{T} \text{ (m/sec}^2\text{)}$$

* For T , use either the acceleration time (t_1) or deceleration time (t_3), whichever is shorter.

③ Accel/decel load F_a (N)

$$F_a = m \times A \text{ (N)}$$

④ Frictional load $F_f = g \times m \times \mu$ (N)

⑤ Total load $F = f \times (F_a + F_f + F_w)$ (N)

Conditions

- Mass m (kg)
- Operating distance l (m)
- Work load F_w (N)
- Friction factor μ
- Kinetic load factor f
- Gravitational acceleration g (m/sec²)
- Acceleration time t_1 (sec)
- Uniform velocity time t_2 (sec)
- Acceleration/deceleration time t_3 (sec)
- Friction factor (μ)
 - Rolling guides 0.005~0.02
 - Sliding guides 0.1~0.2
- Kinetic load factor (f)
 - No shock loads 1.0~1.2
 - Normal 1.2~1.5
 - Shock loads present 1.5~3.0
- Gravitational acceleration (g) 9.8m/sec²

Capacity chart

The thrust values in the capacity chart represent the product of the total mass (the mass of the liner including the reducer and motor and the mass of the load) multiplied by acceleration. The speed is calculated based on the gear ratio, motor size, and roller follower life.

The capacity chart is based on a unit mounted with the reducer and servomotor given in the table below. The capacity depends on the actual reducer and servomotor used.

	Gear ratio of reducer	Servomotor
CS10	3	0.2 kW
CS16	3	0.75 kW
CS22	3	0.75 kW
CS30	3	2.0 kW
CS40	3	3.3 kW

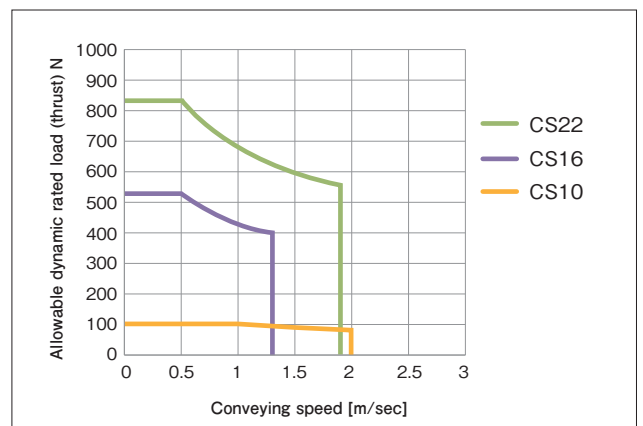
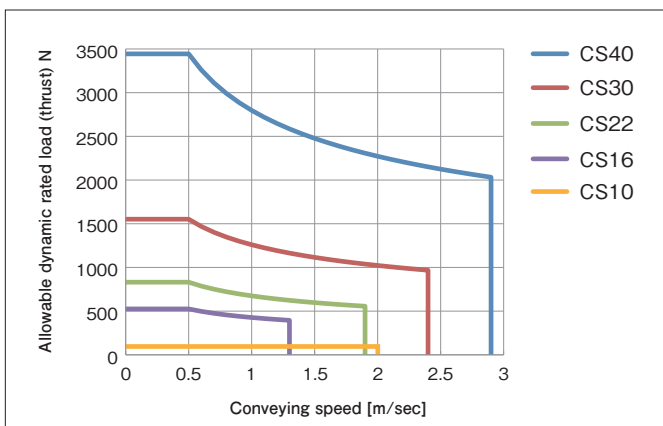

Attention: _____

Date _____

Our contact person: _____

LinerUnit Sizing Form

1. User Specifications							
Company							
Department				Your name			
Address							
TEL				FAX			
Email address							
Application							
Legal regulations and/or user standards <input type="checkbox"/> None <input type="checkbox"/> Applicable ()				Additional information <input type="checkbox"/> None <input type="checkbox"/> Attached			
2. Operating conditions							
Sizes <input type="checkbox"/> CS10 <input type="checkbox"/> CS16 <input type="checkbox"/> CS22 <input type="checkbox"/> CS30 <input type="checkbox"/> CS40				Operating time	Acceleration [sec]		
Conveying target <input type="checkbox"/> Liner <input type="checkbox"/> Rail					Constant velocity [sec]		
Payload [kg]		max CS10:20	max CS16:50		max CS22:75	max CS30:100	max CS40:500
* The figures given above are the actual payloads the Liner can handle. Guides or other supports must be used for heavier loads.					Acceleration/deceleration [sec]		
Stroke length L [mm]					Standby [sec]		
Direction of motion <input type="checkbox"/> Horizontal <input type="checkbox"/> Vertical				Linear guides to be used * Customer-provided LM guides, etc.			
Working load [N]							
3. Technical Info							
【 Formulas for Finding Number of Rails 】 *Round up to the nearest integer.				Rail Connection Bracket <input type="checkbox"/> None <input type="checkbox"/> Yes			
CS10	$X=1+(L-395)/495$ (Component Specification)	Number of Rails: X	Rail materia (Component Specification only selectable) <input type="checkbox"/> Steel <input type="checkbox"/> Aluminum *Aluminum is recommended if the liner is fixed and the rail is moved.				
CS16	$X=1+(L-375)/500$ (Component Specification)						
CS22	$X=1+(L-355)/490$ (Component Specification)						
CS30	$X=1+(L-355)/540$ (Component Specification)						
CS40	$X=1+(L-550)/770$ (Component Specification)						
Servomotor manufacturer <input type="checkbox"/> MITSUBISHI <input type="checkbox"/> YASKAWA <input type="checkbox"/> FANUC <input type="checkbox"/> Others ()							
Servomotor model <div style="text-align: right;">*Customer to prepare servomotor.</div>							
Reducer model number VRB-				[NIDEC-SHIMPO]			
Remarks							

Global network

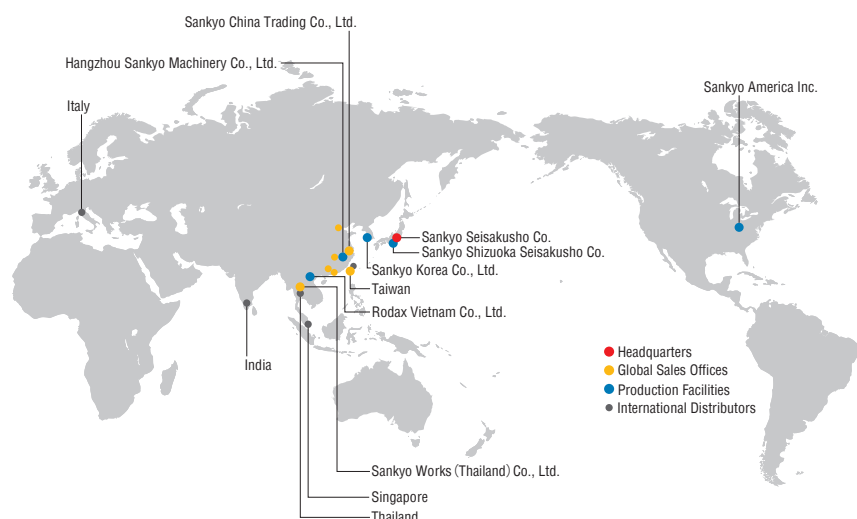

Group Companies

Sankyo America Inc.
10655 State Route 47 Sidney, Ohio, 45365 U.S.A.
Phone: +1-(0)937-498-4901 Fax: +1-(0)937-498-9403
Email: sales@sankyoautomation.com

Sankyo Korea Co., Ltd.
1449-48 Seobu-ro, Gwonseon-gu, Suwon-si, Gyeonggi-do, 16643 Korea
Phone: +82-(0)31-895-5991 Fax: +82-(0)31-895-6607
Email: kr-sales@rollerdrive.com

Sankyo China Trading Co., Ltd.
[Shanghai Sales Office]
Room 1103, Block B, No.391 Guiping Road,
Shanghai 200233 China
Phone: +86-(0)21-5445-2813 Fax: +86-(0)21-5445-2340
Email: sales@sankyo-china-trading.com

[Shenzhen Sales Office]
Unit 19J, Tower B, Neo Building, No.6009 Shennan Avenue,
Futian District, Shenzhen China
Phone: +86-(0)755-8230-0270 Fax: +86-(0)755-8236-4605

[Tianjin Sales Office]
Room 1905, Pengzhanfeiwu Building A, Crossing Yale Road Yaolin Road,
Xiqing District, Tianjin 300380 China
Phone: +86-(0)22-2312-1005 Fax: +86-(0)22-2312-1007

[Guangzhou Sales Office]
Room 913, Xing Pu Building, No.12 Guan Hong Road,
Guangzhou Economic Development Zone, Huang Pu,
Guang Zhou 510670 China
Phone: +86-(0)20-8985-1846 Fax: +86-(0)20-8225-7346

[Wuhan Sales Office]
Room 2301, Taihe Square, No.134 Wusheng Road, Wuhan,
Hubei Province China
Phone: +86-(0)27-8568-5818 Fax: +86-(0)27-8568-2818

Hangzhou Sankyo Machinery Co., Ltd.
No.2518 Jiang Dong 2 Road, Hangzhou Jiang Dong Industrial Park,
Xiaoshan Zone, Hangzhou, Zhejiang, China
Phone: +86-(0)571-8283-3311 Fax: +86-(0)571-8283-1133

Rodax Vietnam Co., Ltd.
Plot No. M1, Thang Long Industrial Park II
Di Su, My Hao, Hung Yen, Viet Nam
Phone: +84-(0)221-3-589701 Fax: +84-(0)221-3-589708

Sankyo Works (Thailand) Co., Ltd.
9/31 Moo 5, Phaholyotin Road, Klongnueng,
Klong Luang, Patumthani 12120 Thailand
Phone: +66-(0)2-516-5355 Fax: +66-(0)2-068-0931
Email: sales@sankyo-works.co.th

Contact us

Mon-Fri AM8:30-12:00 PM13:00-17:30 UTC + 09:00 (JST) (Except public holidays and company holidays)

■ **Headquarters**
(International Sales Division) 3-37-3 Tabatashinmachi, Kita-ku, Tokyo, Japan 114-8538
Phone: +81-(0)3-3800-3330
Fax: +81-(0)3-3800-3380
Email: overseas@sankyo-seisakusho.co.jp
URL: <http://www.sankyo-seisakusho.co.jp>

■ **Taiwan Sales Office** No.21, Ln.152, Jianxing Rd., Sanhe Vil., Daya Dist., Taichung City 42876, Taiwan (R.O.C.)
Phone: +886-(0)4-2359-4048
Fax: +886-(0)4-2359-4720
Email: tw-sales@rollerdrive.com



<http://www.sankyo-seisakusho.co.jp>

*No part of this brochure may be reproduced, transferred,
or distributed without the express consent of Sankyo Seisakusho Co.
*Specifications and dimensions are subject to change without notice.
Consult Sankyo sales before ordering.