

Dimensional drawing

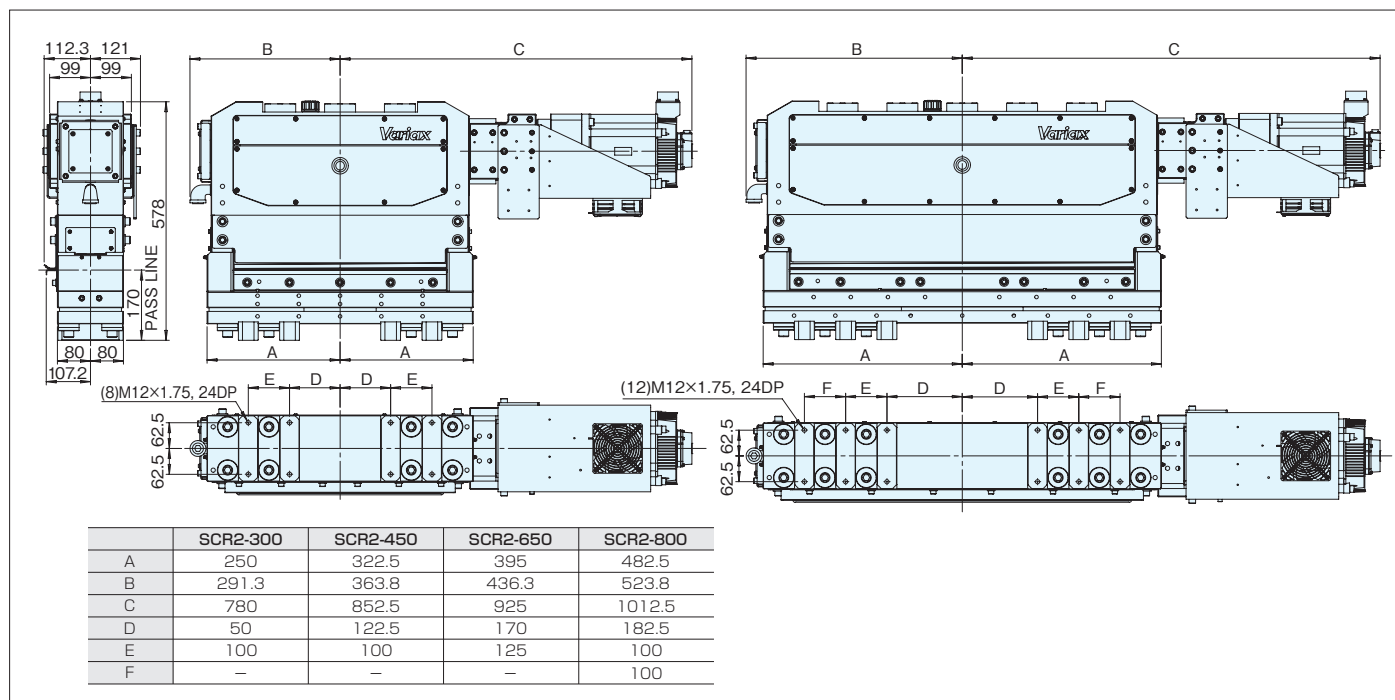

Example of installation

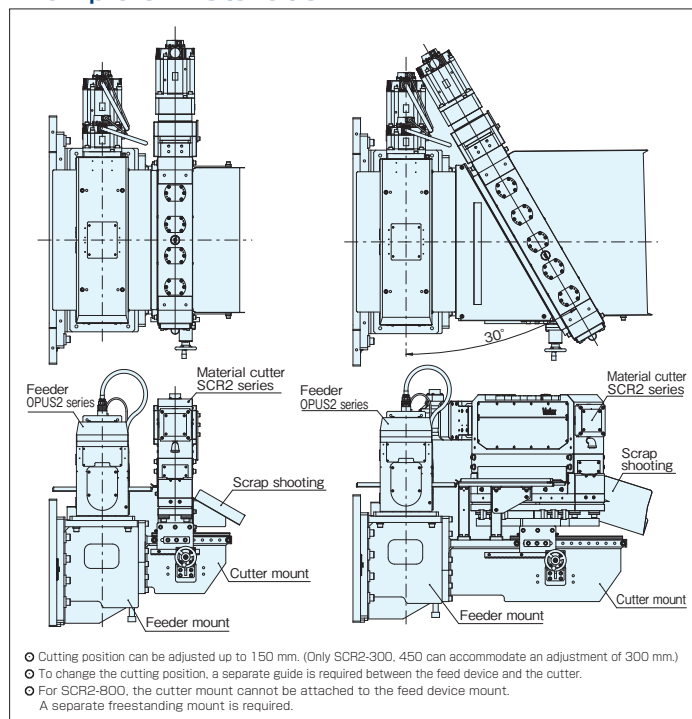

Control panel dimensional drawings

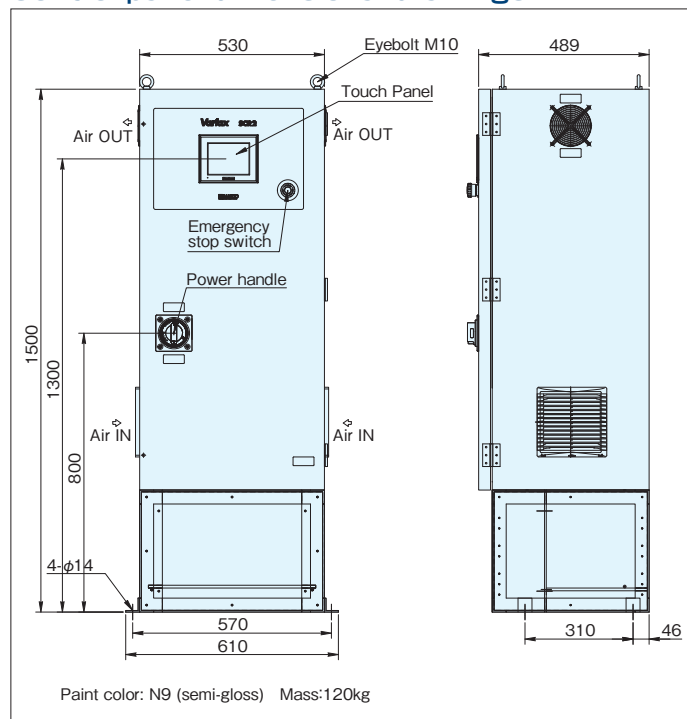

Specification table

Item	Unit	SCR2-300	SCR2-450	SCR2-650	SCR2-800	Remarks
Maximum cut material width	mm	300	450	650	800	
		220	345	470	620	When installed at an angle of 30°
		370	515	660	835	Cutter blade width
Material thickness	mm	0.1~0.5				
Cut off load	N	18,000	28,000	40,000	40,000	
		5,600	5,600	8,100	10,000	Continuous production
Synchronized speed	min ⁻¹	400				
Mass	kg	295	350	405	480	



■ **Headquarters (International Sales Division)**
 3-37-3 Tabatashinmachi Kita-ku Tokyo Japan 114-8538
 Phone: +81-(0)3-3800-3305 Fax: +81-(0)3-3800-3378
 Email: overseas@sankyo-seisakusho.co.jp

■ **Sankyo Korea Co., Ltd.**
 Phone: +82-(0)31-895-5991 Email: kr-sales@rollerdrive.com

■ **Sankyo Seisakusho Co. Taiwan Branch**
 Phone: +886-(0)4-2359-4048 Email: tw-sales@rollerdrive.com

■ **Sankyo Works (Thailand) Co., Ltd.**
 Phone: +66-(0)2-516-5355 Email: sales@sankyo-works.co.th

■ **Sankyo America Inc.**
 Phone: +1-(0)937-498-4901
 Email: sales@sankyoautomation.com

■ **Sankyo China Trading Co., Ltd.**
 Phone: +86-(0)21-5445-2813
 Email: sales@sankyochina-trading.com