

World's thinnest scrap cutter Scrap cutter SCR2 series

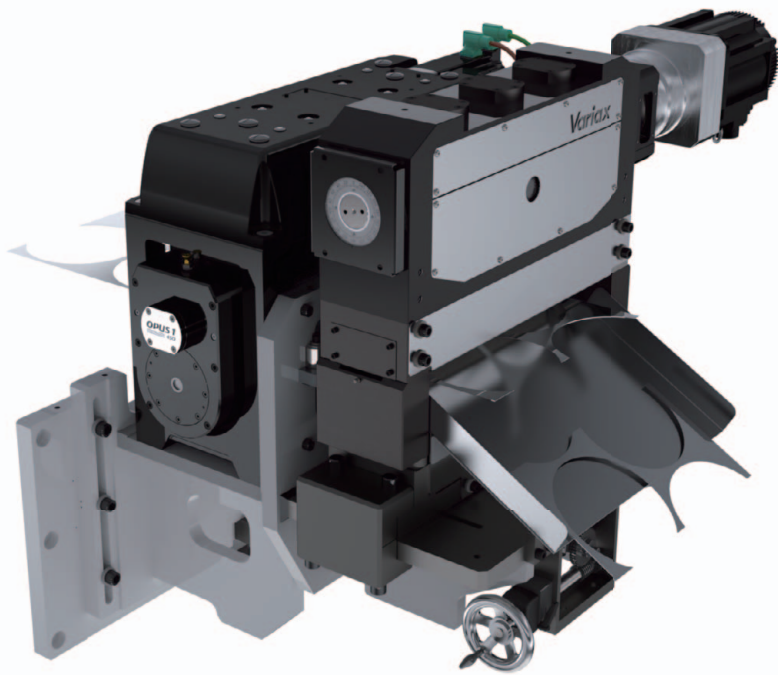

PRECISION ADJUSTABLE FEED

Variax SCR2-450,650

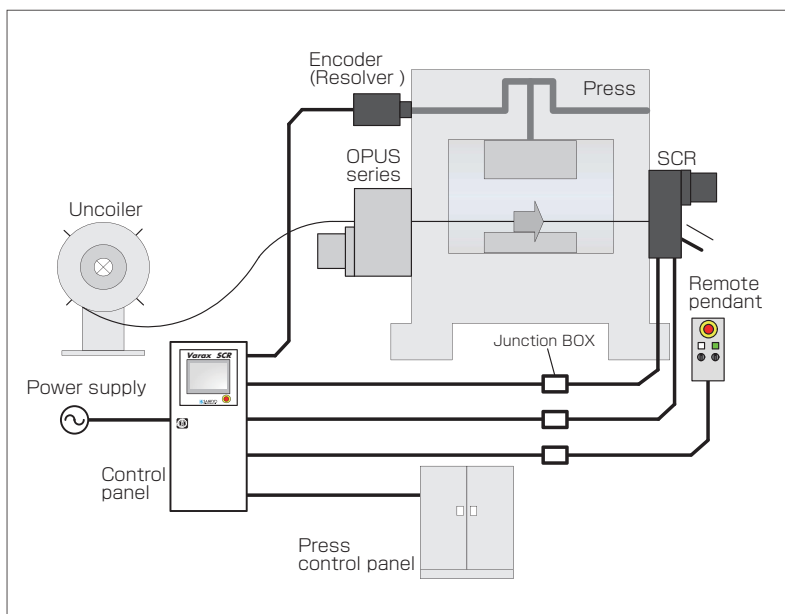

Overview

The SCR2 series is a scrap cutter that uses the thinnest cutting mechanism (160 mm) in the world. Since it is the thinnest, it can be installed close to the feeder, which reduces problems when transporting skeleton materials for conventional products, making synchronized high-speed press operation possible.

Features

Compact

Has the world's thinnest cutter (160 mm).
Saves space and speeds up press line operations.

Stable cutting

It offers stable cutting of thin plate materials thanks to its back stopper.

Maintenance

Easy replacement of cutting blades.

And...

The cutting position can be adjusted.

Other functions

Monitoring function

You can check the motor torque on the monitor while cutting (touch panel)

Set up position adjustment

The cutting position can be adjusted.

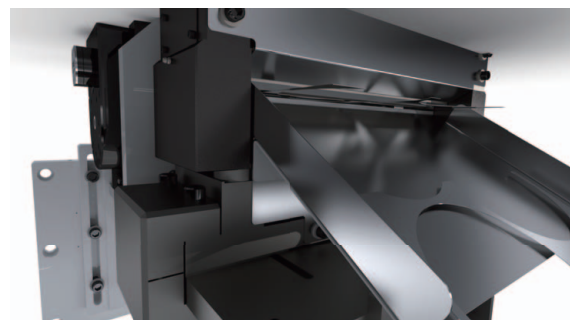

Dimensional drawing

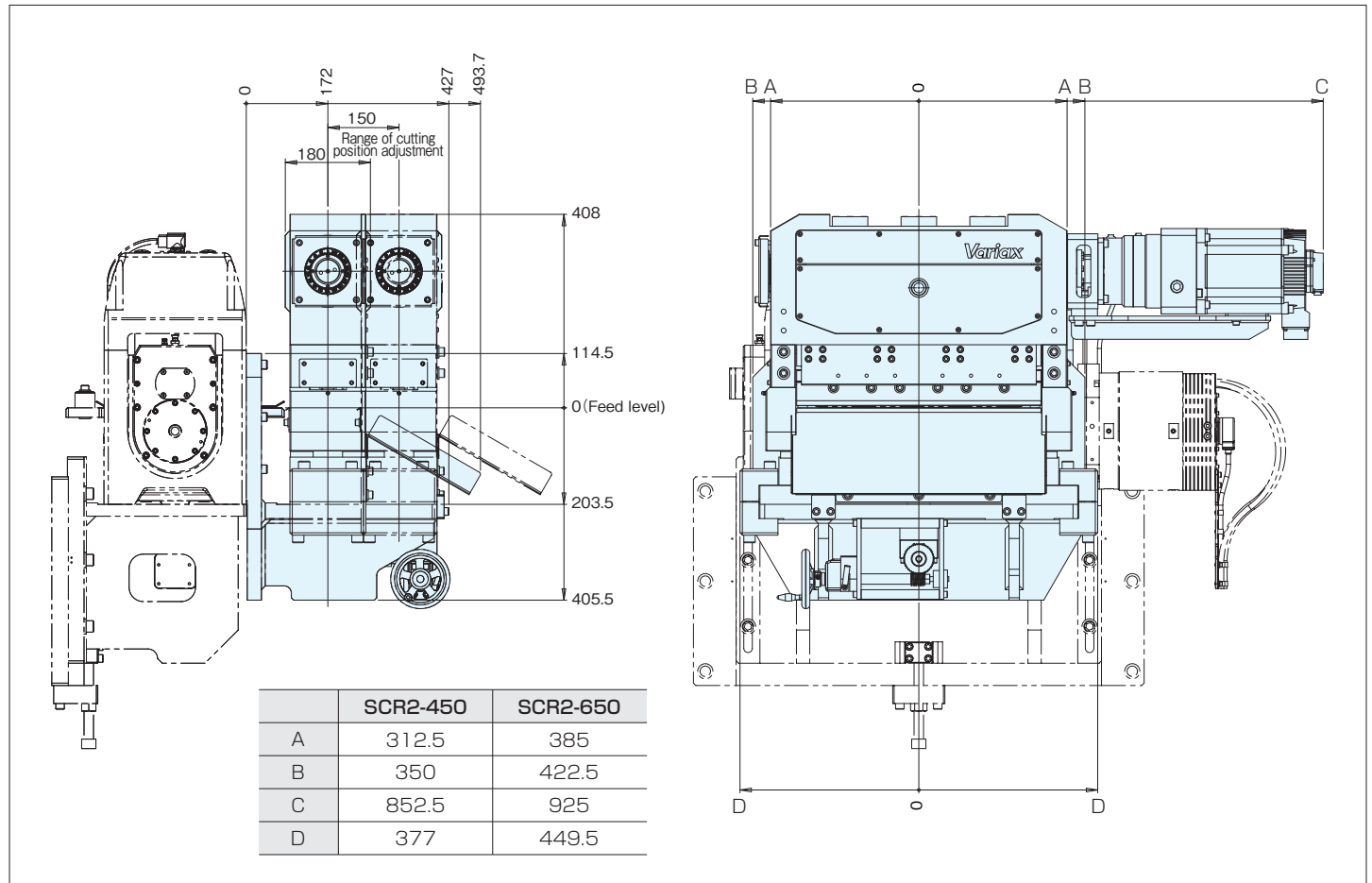

Specification table

Item	Unit	SCR2-450	SCR2-650
Maximum cut material width	mm	450	650
		350 (30° setting)	470 (30° setting)
		(Cutter width: 510)	(Cutter width: 660)
Material thickness	mm	0.1~0.5	0.1~0.5
Cut off load	N	40,000	40,000
Stripper load	N	6,000	6,000
Synchronized speed	min ⁻¹	500	500
Servomotor		YASKAWA	
Mass	kg	240 (main housing only)	260 (main housing only)

Control panel dimensional drawings

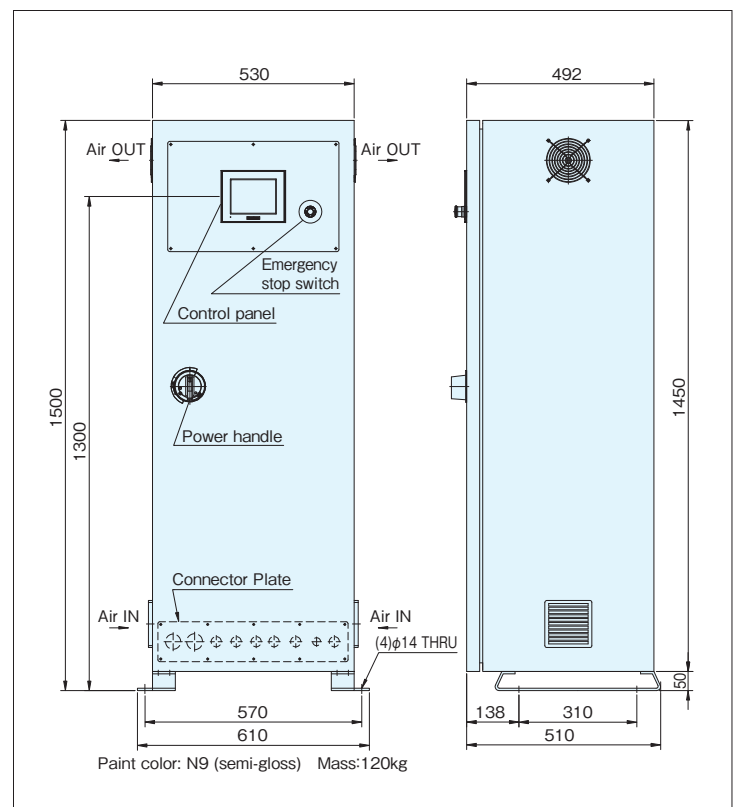

■ **Headquarters (International Sales Division)**
 3-37-3 Tabatashinmachi Kita-ku Tokyo Japan 114-8538
 Phone: +81-(0)3-3800-3330 Fax: +81-(0)3-3800-3380
 Email: overseas@sankyo-seisakusho.co.jp

■ **Sankyo Korea Co., Ltd.**
 Phone: +82-(0)31-895-5991 Email: kr-sales@rollerdrive.com

■ **Sankyo Seisakusho Co. Taiwan Branch**
 Phone: +886-(0)4-2359-4048 Email: tw-sales@rollerdrive.com

■ **Sankyo Works (Thailand) Co., Ltd.**
 Phone: +66-(0)2-516-5355 Email: sales@sankyo-works.co.th

■ **Sankyo America Inc.**
 Phone: +1-(0)937-498-4901
 Email: sales@sankyoautomation.com

■ **Sankyo China Trading Co., Ltd.**
 Phone: +86-(0)21-5445-2813
 Email: sales@sankyochina-trading.com