



### 2.8D/2.8E Dimensions

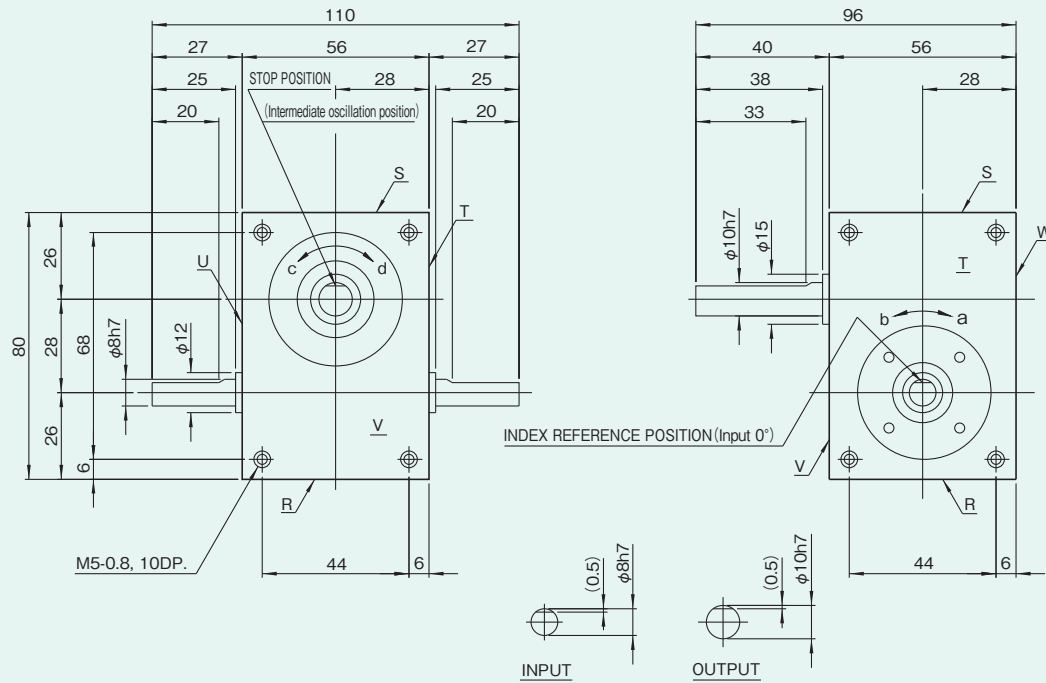
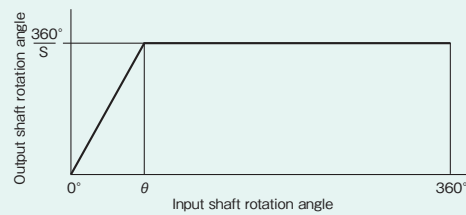

Figure 2.8D-1

### Timing chart

#### ●Indexing drive 2.8D

Figure 2.8D-2



#### ●Oscillating drive 2.8E

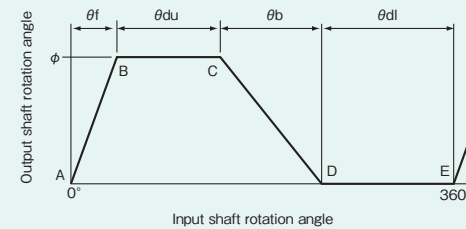

S : Number of stops  
 $\theta$  : Index period  
 $\phi$  : Oscillating angle  
 $\theta_f$  : Forward oscillation angle.  
 Input shaft rotation angle required for the output shaft to rotate by  $\phi^\circ$  from the reference position.

$\theta_{du}$  : Upper dwell angle.  
 The rotation angle of the input shaft when the output shaft is at a position of  $\phi^\circ$  from the reference position.  
 $\theta_b$  : Reverse oscillation angle.  
 $\theta_{dl}$  : Lower dwell angle.

### Specifications

Table 2.8D-1

Item	Symbol	Unit	Value
Output allowable axial load	$P_1$	N	245
Output allowable radial load	$P_2$	N	245
Output static torque	$T_s$	N·m	Refer to Torque Capacity Table
Output torsional rigidity	$K_1$	N·m/rad	800
Output inertia	$J_o$	kg·m <sup>2</sup>	$5 \times 10^{-6}$
Output allowable bending moment	$P_3$	N·m	3.7
Input allowable axial load	$P_4$	N	196
Input maximum repetitive bending force	$P_5$	N	196
Input maximum repetitive allowable torque	$P_6$	N·m	7.84
Input torsional rigidity	$K_2$	N·m/rad	380
Input inertia	$J_1$	kg·m <sup>2</sup>	$3.75 \times 10^{-5}$
Indexing accuracy		sec	$\pm 72$
Product weight		kg	1.25

Note : Input inertia :  
 J is calculated in dwell. (1N·m=0.102kgf·m)

### Mounted accessories (OPUS1)

#### 2.8D (a)

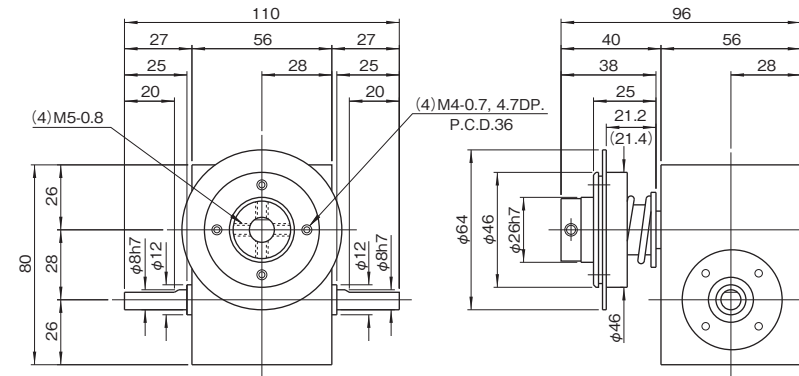

Example Model Code  
 Indexing Drive  
 2.8D - 04277R - L3VW 1  
 Torque Limiter  
 4 TF - 010 C

#### 2.8D (b)

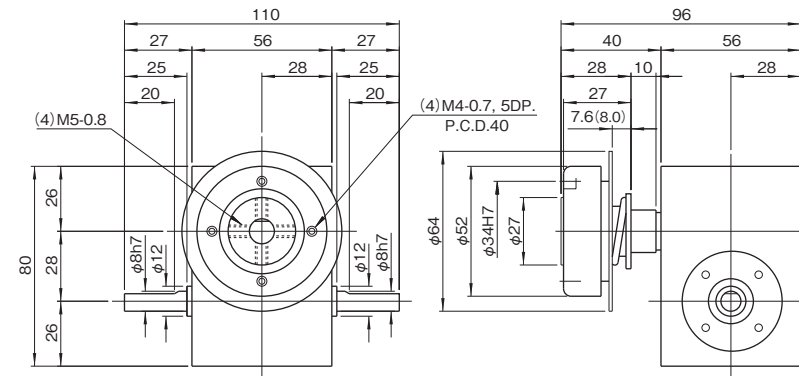

Example Model Code  
 Indexing Drive  
 2.8D - 06187L - L3VW 1  
 Torque Limiter  
 4 TC - 007 C

### Precautions

- The same drawing applies for a 2.8E equipped with a 4TF and 4TC.
- Some dimensions are given in parenthesis for certain types of torque limiters. When selecting a torque limiter, always check dimension L.

### Timing cam-Photo switch

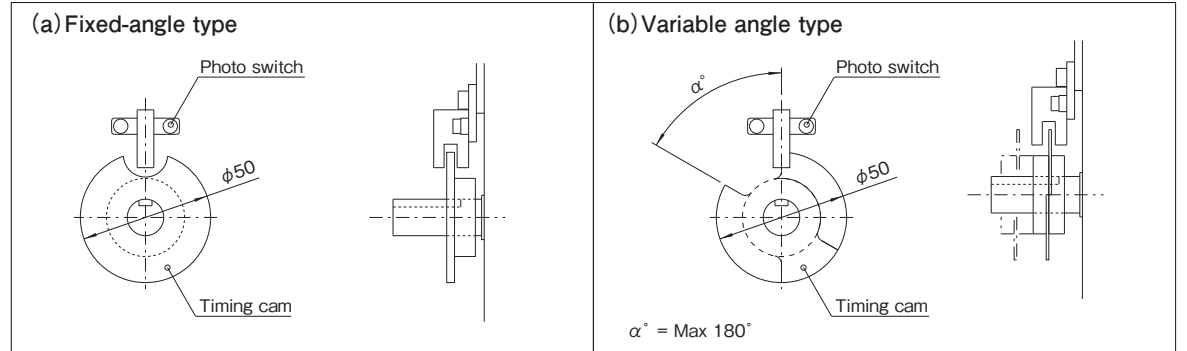

※Up to 2 sets of timing cams and photo switches can be added as necessary.

Mounted accessories (OPUS2)

2.8D

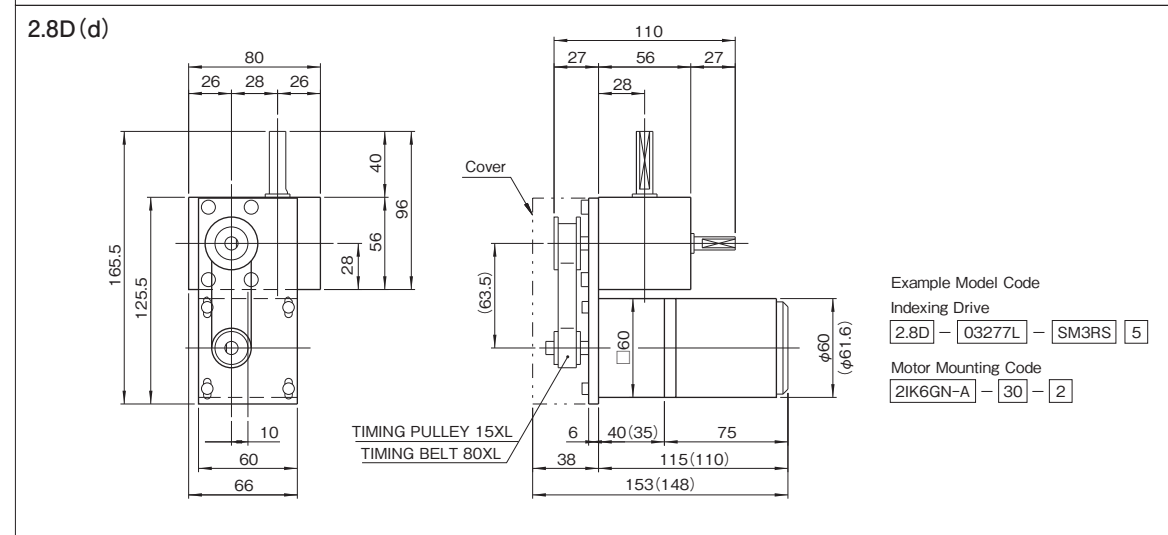
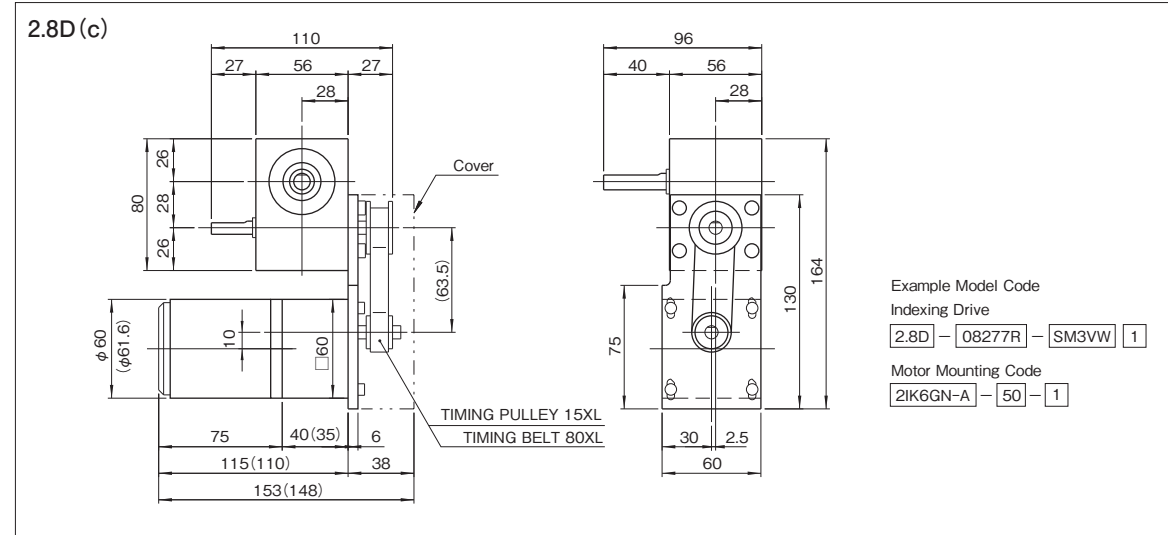

Mounted accessories (OPUS3)

2.8D

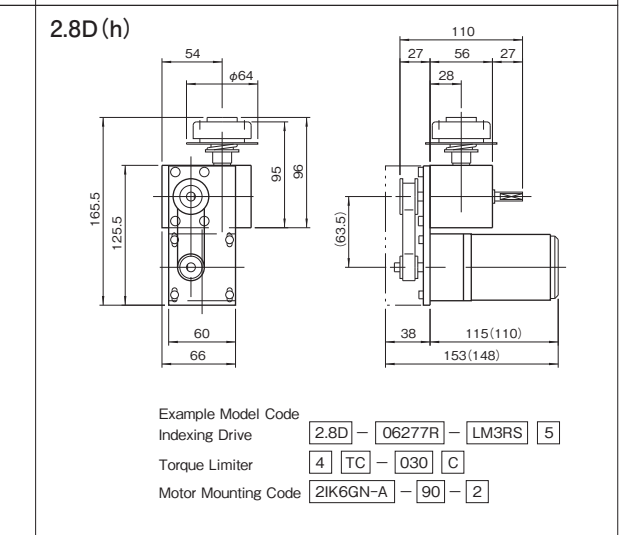
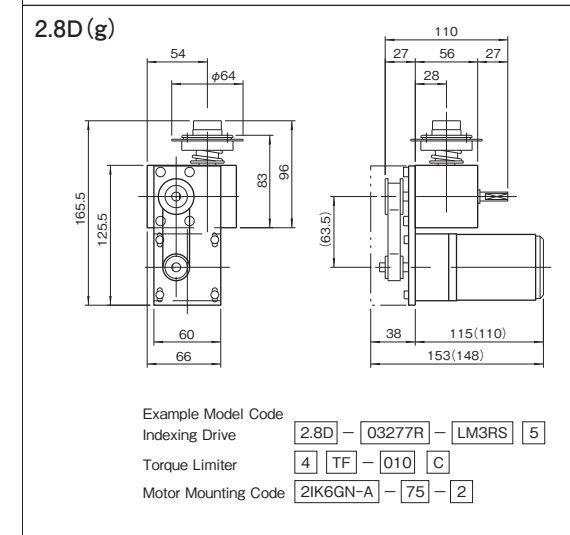
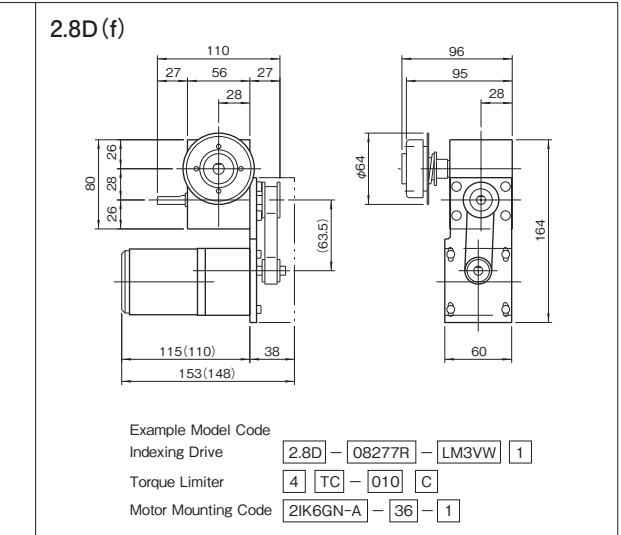
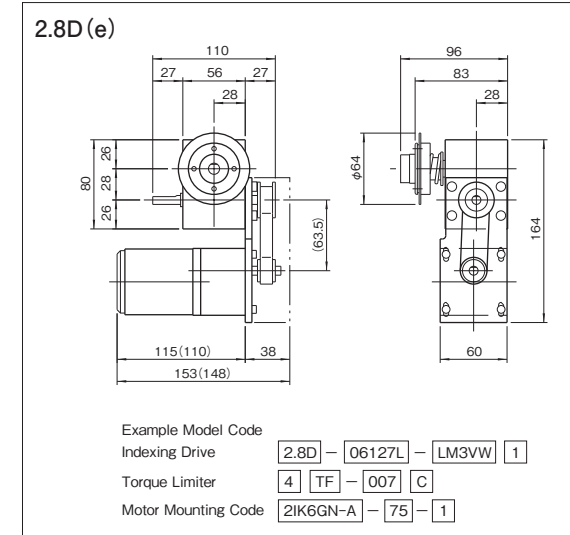

Induction motor specifications

Table 2.8D-2

Motor model	Output power (W)	Frequency (Hz)	Voltage (V)	Current (A)	Starting torque (N·m)	Rated torque (N·m)	Rotating speed (rpm)	Capacitor (μF)	Gear head model	
									Ball bearing type	Intermediate gear head
Oriental Motor	2IK6GN-A	6	50 60	100	0.25 0.045 0.040	0.050 0.040	1200 1450	2.5	2GN□K	2GN10XK
Panasonic	M6LA6G4L	6	50 60	100	0.22 0.20	0.047 0.036	1200 1550	2.5	M6GA□B	M6GA10XK

Allowable torque with gear head (N·m)

Table 2.8D-3

Rotating speed rpm	Allowable torque (N·m)														
	200	120	100	60	50	30	20	15	10	6	5	3	2	1.5	1
50Hz Gear ratio	7.5	12.5	15	25	30	50	75	100	150	250	300	500	750	1000	1500
60Hz Gear ratio	9	15	18	30	36	60	90	120	180	300	360	600	900	1200	1800
Allowable torque	2IK6GN-A	0.3	0.51	0.61	0.91	1.1	1.7	2.5	3.0	3.0	3.0	3.0	3.0	3.0	3.0
	M6LA6G4L	0.25	0.40	0.49	0.79	0.95	1.57	2.25	2.45	2.45	2.45	2.45	2.45	2.45	2.45

Bold numbers are the values at which the intermediate gear head is connected directly to the index.

(1N·m=0.102kgf·m)

The rotation speed is calculated by dividing by the reduction ratio based on the synchronous rotation speed of the motor (50Hz: 1500rpm, 60Hz: 1800rpm).

Precautions

- The mounting base of the motor mounts on the sides T or U of the indexing drive as shown in Figure 2.8D-(c),(d).
- Figure 2.8D-(c),(d) shows the opposite of when mounted on side U.
- Dimensions in parenthesis Panasonic motor.
- When ordering, always specify the gear reduction ratio along with the indexing drive code number.
- Note:For details on the induction motor, refer to the brochure for Oriental Motors(or Panasonic).
- The overall length of the motor will be less, depending on the reduction ratio.



Mounted accessories (OPUS2)

3.8D

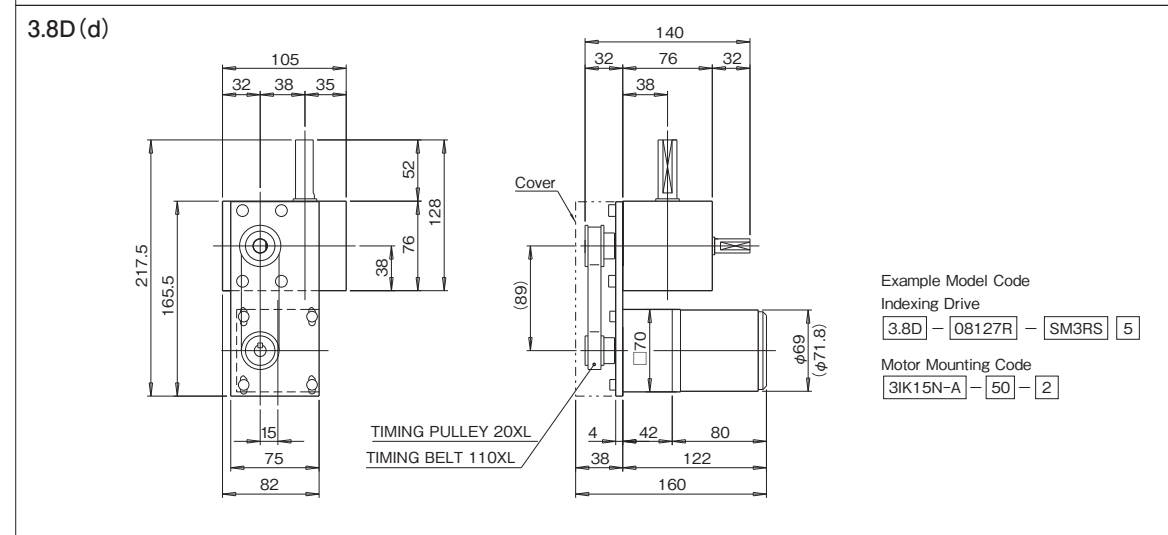
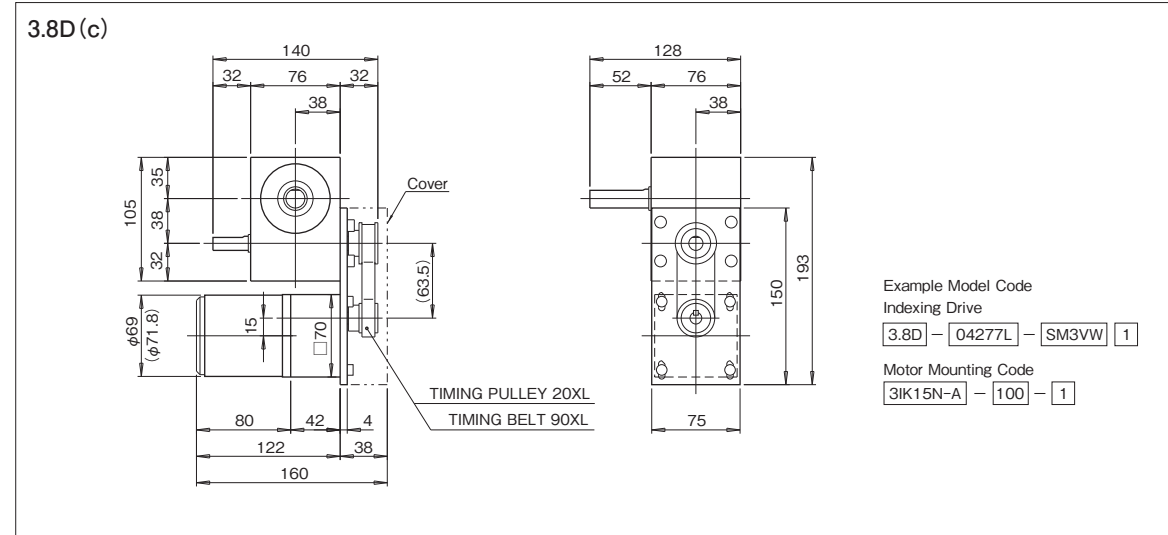

Induction motor specifications

Table 3.8D-2

Motor model	Output power (W)	Frequency (Hz)	Voltage (V)	Current (A)	Starting torque (N·m)	Rated torque (N·m)	Rotating speed (rpm)	Capacitor (μF)	Gear head model	
									Ball bearing type	Intermediate gear head
Oriental Motor	3IK15GN-A	15	50 60	100	0.4 0.080 0.065	0.120 0.095	1250 1550	4.0	3GN□K	3GN10XK
Panasonic	M7IA15G4L	15	50 60	100	0.36 0.34	0.088	1300 1600	4.0	M7GA□B	M7GA10XK

Allowable torque with gear head (N·m)

Table 3.8D-3

Rotating speed rpm	Allowable torque (N·m)														
	200	120	100	60	50	30	20	15	10	6	5	3	2	1.5	1
50Hz Gear ratio	7.5	12.5	15	25	30	50	75	100	150	250	300	500	750	1000	1500
60Hz Gear ratio	9	15	18	30	36	60	90	120	180	300	360	600	900	1200	1800
Allowable torque	3IK15GN-A		0.73	1.2	1.5	2.2	2.6	4.0	5.0	5.0	5.0	5.0	5.0	5.0	5.0
	M7IA15G4L		0.59	0.98	1.18	1.86	2.25	3.82	4.90	4.90	4.90	4.90	4.90	4.90	4.90

Bold numbers are the values at which the intermediate gear head is connected directly to the index. (1N·m=0.102kgf·m)

The rotation speed is calculated by dividing by the reduction ratio based on the synchronous rotation speed of the motor (50Hz: 1500rpm, 60Hz: 1800rpm).

Mounted accessories (OPUS2)

3.8D

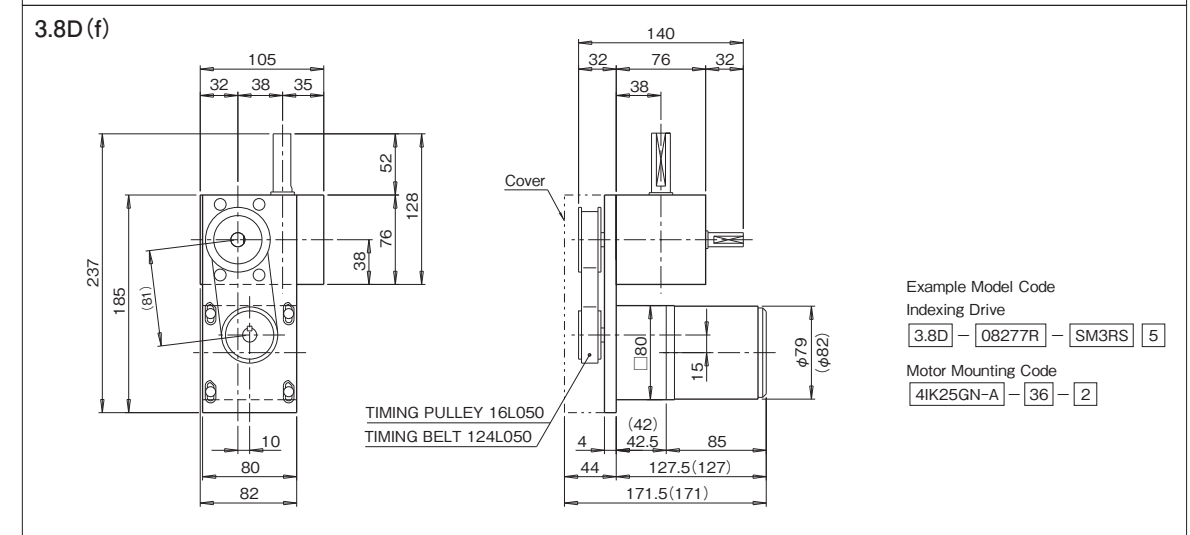
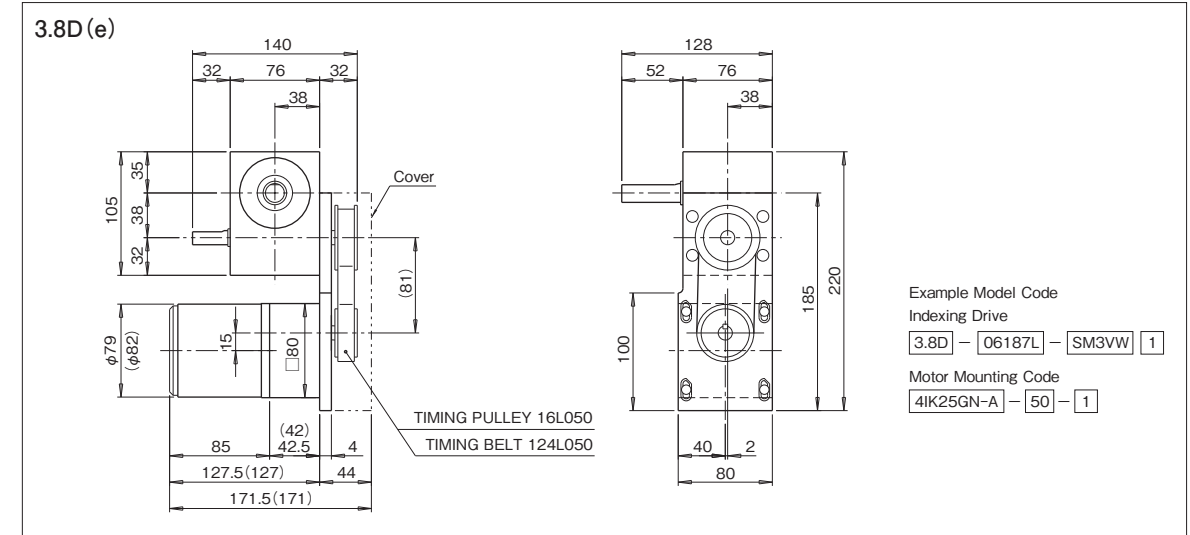

Induction motor specifications

Table 3.8D-4

Motor model	Output power (W)	Frequency (Hz)	Voltage (V)	Current (A)	Starting torque (N·m)	Rated torque (N·m)	Rotating speed (rpm)	Capacitor (μF)	Gear head model		
									Ball bearing type	Intermediate gear head	
Oriental Motor	4IK25GN-A	25	50 60	100	0.65 0.6	0.13 0.11	0.19 0.16	1250 1550	6.0	4GN□K	4GN10XK
Panasonic	M8IA25G4L	25	50 60	100	0.57 0.48	0.137	0.176 0.147	1325 1625	6.0	M8GA□B	M8GA10XK

Allowable torque with gear head (N·m)

Table 3.8D-5

Rotating speed rpm	Allowable torque (N·m)														
	200	120	100	60	50	30	20	15	10	6	5	3	2	1.5	1
50Hz Gear ratio	7.5	12.5	15	25	30	50	75	100	150	250	300	500	750	1000	1500
60Hz Gear ratio	9	15	18	30	36	60	90	120	180	300	360	600	900	1200	1800
Allowable torque	4IK25GN-A		1.2	1.9	2.3	3.5	4.2	6.3	8.0	8.0	8.0	8.0	8.0	8.0	8.0
	M8IA25G4L		0.98	1.57	1.96	3.14	3.82	6.37	7.84	7.84	7.84	7.84	7.84	7.84	7.84

Bold numbers are the values at which the intermediate gear head is connected directly to the index. (1N·m=0.102kgf·m)

The rotation speed is calculated by dividing by the reduction ratio based on the synchronous rotation speed of the motor (50Hz: 1500rpm, 60Hz: 1800rpm).

Precautions

- The mounting base of the motor mounts on the sides T or U of the indexing drive as shown in Figure 3.8D-(c),(d).
- Figure 3.8D-(c),(d) shows the opposite of when mounted on side U.
- Dimensions in parenthesis Panasonic motor.
- When ordering, always specify the gear reduction ratio along with the indexing drive code number.
- Note:For details on the induction motor, refer to the brochure for Oriental Motors(or Panasonic).
- The overall length of the motor will be less, depending on the reduction ratio.

Precautions

- The mounting base of the motor mounts on the sides T or U of the indexing drive as shown in Figure 3.8D-(e),(f).
- Figure 3.8D-(e),(f) shows the opposite of when mounted on side U.
- Dimensions in parenthesis Panasonic motor.
- When ordering, always specify the gear reduction ratio along with the indexing drive code number.
- Note:For details on the induction motor, refer to the brochure for Oriental Motors(or Panasonic).
- The overall length of the motor will be less, depending on the reduction ratio.

Mounted accessories (OPUS3)

3.8D

3.8D (g)

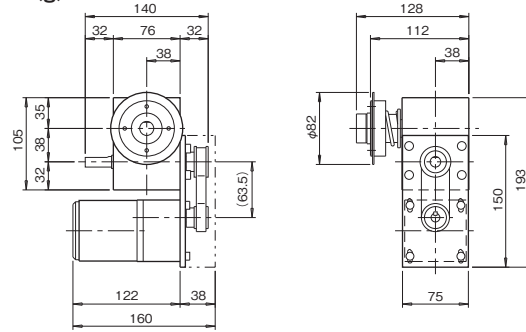

Example Model Code  
 Indexing Drive **3.8D** - **10187R** - **LM3VW** **1**  
 Torque Limiter **5** **TF** - **030** **C**  
 Motor Mounting Code **3IK15GN-A** - **120** - **1**

3.8D (h)

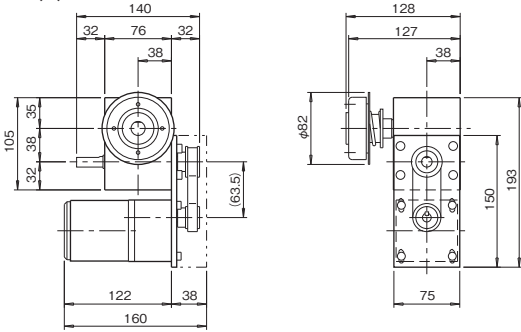

Example Model Code  
 Indexing Drive **3.8D** - **08097L** - **LM3VW** **1**  
 Torque Limiter **5** **TC** - **030** **C**  
 Motor Mounting Code **3IK15GN-A** - **100** - **1**

3.8D (i)

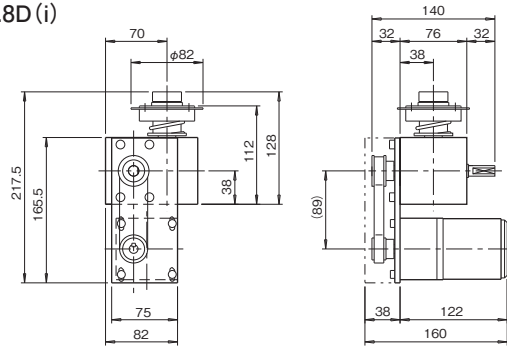

Example Model Code  
 Indexing Drive **3.8D** - **06187R** - **LM3RS** **5**  
 Torque Limiter **5** **TF** - **100** **C**  
 Motor Mounting Code **3IK15GN-A** - **75** - **2**

3.8D (j)

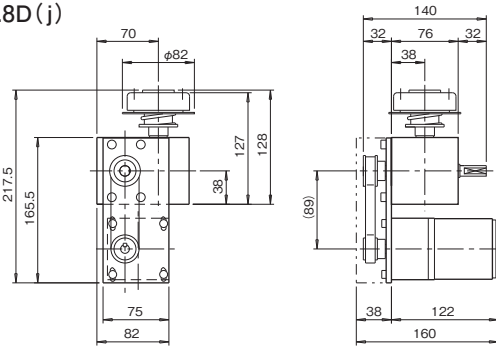

Example Model Code  
 Indexing Drive **3.8D** - **03187R** - **LM3RS** **5**  
 Torque Limiter **5** **TC** - **060** **C**  
 Motor Mounting Code **3IK15GN-A** - **25** - **2**

Mounted accessories (OPUS3)

3.8D

3.8D (k)

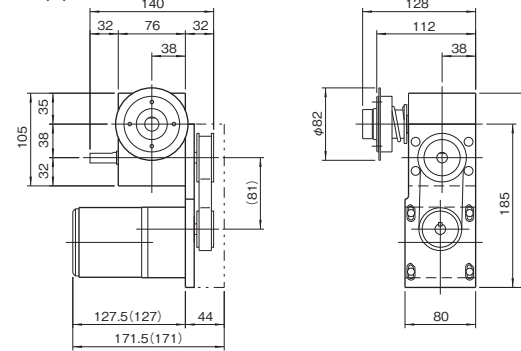

Example Model Code  
 Indexing Drive **3.8D** - **03277R** - **LM3VW** **1**  
 Torque Limiter **5** **TF** - **060** **C**  
 Motor Mounting Code **4IK25GN-A** - **120** - **1**

3.8D (l)

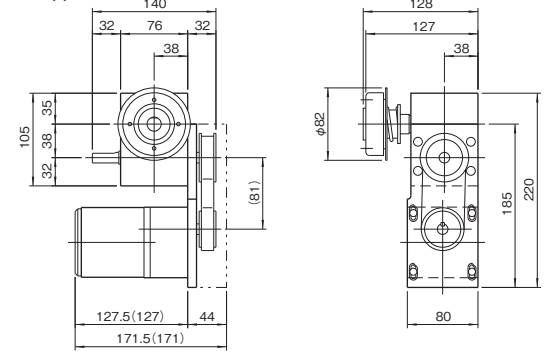

Example Model Code  
 Indexing Drive **3.8D** - **10277L** - **LM3VW** **1**  
 Torque Limiter **5** **TC** - **030** **C**  
 Motor Mounting Code **4IK25GN-A** - **60** - **1**

3.8D (m)

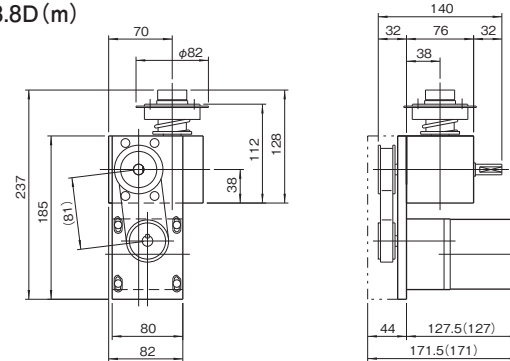

Example Model Code  
 Indexing Drive **3.8D** - **05277R** - **LM3RS** **5**  
 Torque Limiter **5** **TF** - **060** **C**  
 Motor Mounting Code **4IK25GN-A** - **30** - **2**

3.8D (n)

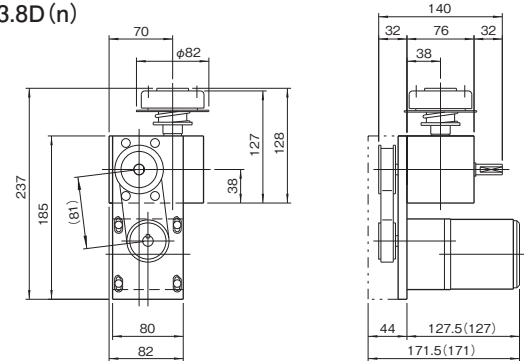

Example Model Code  
 Indexing Drive **3.8D** - **06097R** - **LM3RS** **5**  
 Torque Limiter **5** **TC** - **100** **C**  
 Motor Mounting Code **4IK25GN-A** - **75** - **2**



## 7MI Dimensions

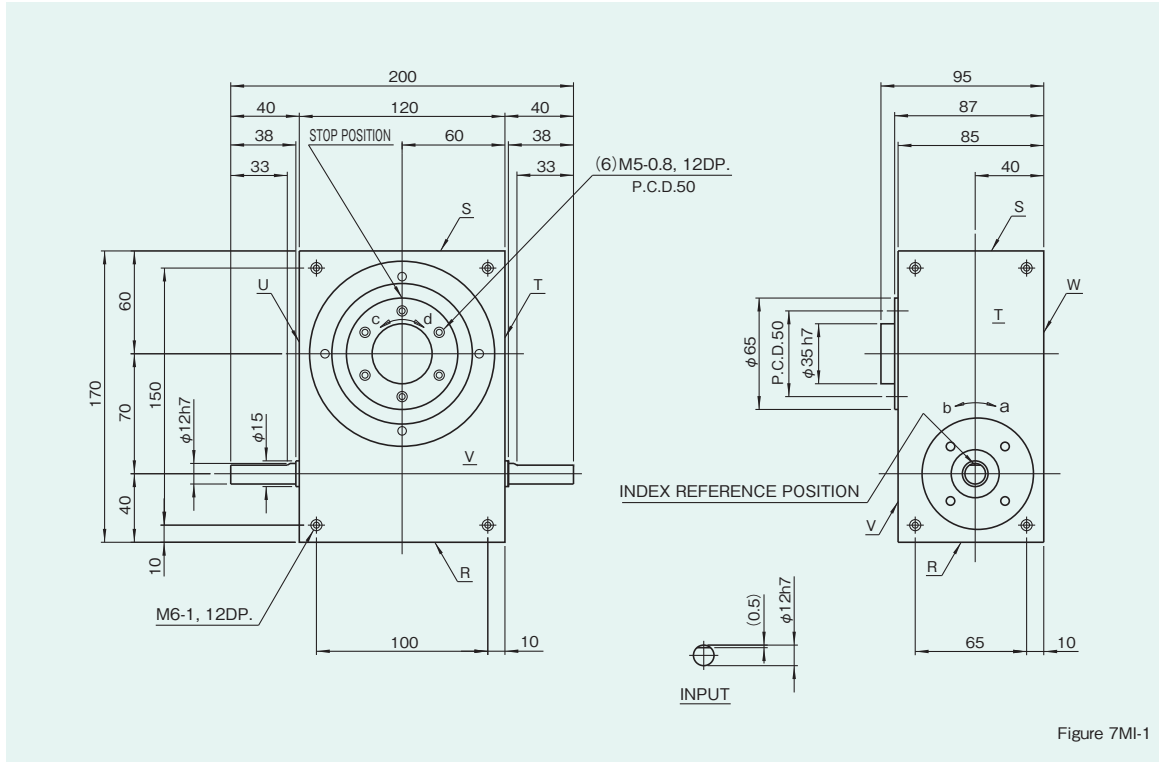
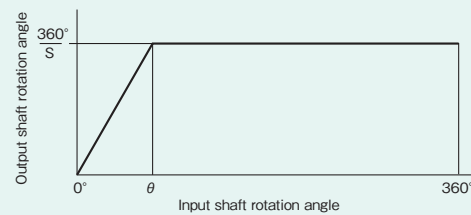

Figure 7MI-1

## Timing chart

### ●1DWELL type

Figure 7MI-2



### ●2DWELL type

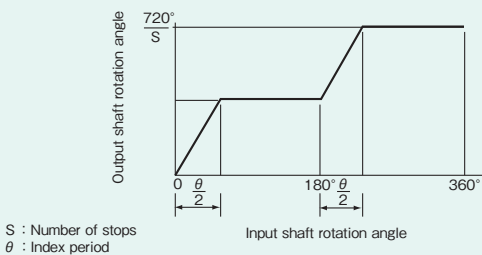

S : Number of stops  
 $\theta$  : Index period

## Specifications

Table 7MI-1

Item	Symbol	Unit	Value
Output allowable axial load	$P_1$	N	980
Output allowable radial load	$P_2$	N	980
Output static torque	$T_s$	N·m	Refer to Torque Capacity Table
Output torsional rigidity	$K_1$	N·m/rad	20000
Output inertia	$J_o$	kg·m <sup>2</sup>	$2 \times 10^{-3}$
Output allowable bending moment	$P_3$	N·m	89
Input allowable axial load	$P_4$	N	343
Input maximum repetitive bending force	$P_5$	N	343
Input maximum repetitive allowable torque	$P_6$	N·m	24.5
Input torsional rigidity	$K_2$	N·m/rad	1300
Input inertia	$J_1$	kg·m <sup>2</sup>	$45 \times 10^{-4}$
Indexing accuracy		sec	$\pm 72$
Product weight		kg	10

Note : Input inertia :  
 $J$  is calculated in dwell. (1N·m=0.102kgf·m)

## Mounted accessories (OPUS1)

### 7MI (a)

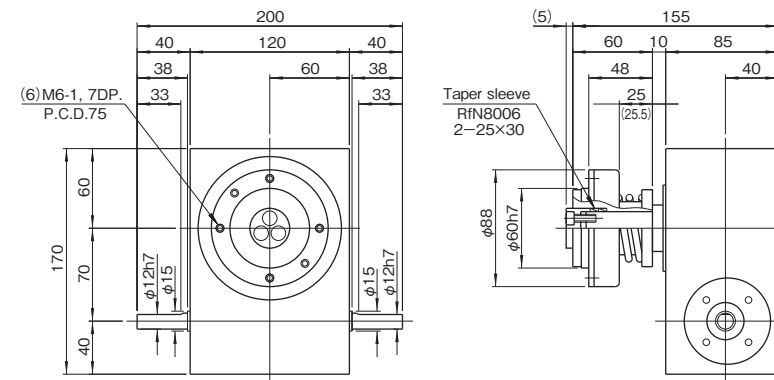

Example Model Code  
 Indexing Drive  
 7MI - 16277R - L3VW 1  
 Torque Limiter  
 6 TF - 3 C

### 7MI (b)

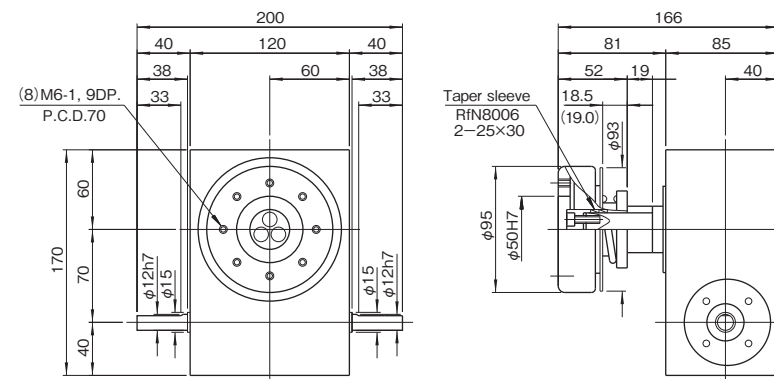

Example Model Code  
 Indexing Drive  
 7MI - 24277L - L3VW 1  
 Torque Limiter  
 6 TC - 3 C

## Hollow shaft dimensions

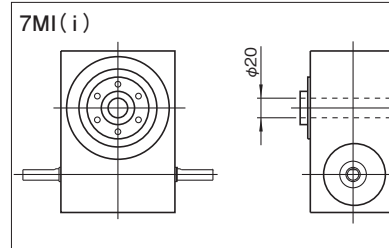

## Precautions

※The hollow shaft version is a special specification. Please contact us for the shape, dimensions and specifications. (The hole diameter in the figure on the left is a standard dimension.)

Mounted accessories (OPUS2)

**7MI(c)**

Example Model Code  
Indexing Drive **7MI** - **16187R** - **SM3VW** **1**  
Motor Mounting Code **4IK25GN-A** - **180** - **1**

TIMING PULLEY 25XL  
TIMING BELT 110XL

**7MI(d)**

Example Model Code  
Indexing Drive **7MI** - **20187L** - **SM3RS** **5**  
Motor Mounting Code **4IK25GN-A** - **60** - **2**

TIMING PULLEY 25XL  
TIMING BELT 110XL

Mounted accessories (OPUS3)

**7MI(e)**

Example Model Code  
Indexing Drive **7MI** - **20277R** - **LM3VW** **1**  
Torque Limiter **6** **TF** - **07** **C**  
Motor Mounting Code **4IK25GN-A** - **150** - **1**

**7MI(f)**

Example Model Code  
Indexing Drive **7MI** - **16187L** - **LM3VW** **1**  
Torque Limiter **6** **TC** - **06** **C**  
Motor Mounting Code **4IK25GN-A** - **180** - **1**

**7MI(g)**

Example Model Code  
Indexing Drive **7MI** - **12127R** - **LM3RS** **5**  
Torque Limiter **6** **TF** - **1** **C**  
Motor Mounting Code **4IK25GN-A** - **90** - **2**

**7MI(h)**

Example Model Code  
Indexing Drive **7MI** - **20277R** - **LM3RS** **5**  
Torque Limiter **6** **TC** - **1** **C**  
Motor Mounting Code **4IK25GN-A** - **120** - **2**

Induction motor specifications

Table 7MI-2

Motor model	Output power (W)	Frequency (Hz)	Voltage (V)	Current (A)	Starting torque (N·m)	Rated torque (N·m)	Rotating speed (rpm)	Capacitor (μ F)	Gear head model	
									Ball bearing type	Intermediate gear head
Oriental Motor 4IK25GN-A	25	50 60	100	0.65 0.6	0.13 0.11	0.19 0.16	1250 1550	6.0	4GN□K	4GN10XK
Panasonic M81A25G4L	25	50 60	100	0.57 0.48	0.137	0.176 0.147	1325 1625	6.0	M8GA□B	M8GA10XK

Allowable torque with gear head (N·m)

Table 7MI-3

Rotating speed rpm	200	120	100	60	50	30	20	15	10	6	5	3	2	1.5	1
50Hz Gear ratio	7.5	12.5	15	25	30	50	75	100	150	250	300	500	750	1000	1500
60Hz Gear ratio	9	15	18	30	36	60	90	120	180	300	360	600	900	1200	1800
Allowable torque	4IK25GN-A		1.2	1.9	2.3	3.5	4.2	6.3	8.0	8.0	<b>8.0</b>	<b>8.0</b>	<b>8.0</b>	<b>8.0</b>	<b>8.0</b>
	M81A25G4L		0.98	1.57	1.96	3.14	3.82	6.37	7.84	7.84	<b>7.84</b>	<b>7.84</b>	<b>7.84</b>	<b>7.84</b>	<b>7.84</b>

Bold numbers are the values at which the intermediate gear head is connected directly to the index.

(1N·m=0.102kgf·m)

The rotation speed is calculated by dividing by the reduction ratio based on the synchronous rotation speed of the motor (50Hz: 1500rpm, 60Hz: 1800rpm).

Precautions

- The mounting base of the motor mounts on the sides T or U of the indexing drive as shown in Figure 7MI-(c),(d).
- Figure 7MI-(c),(d) shows the opposite of when mounted on side U.
- Dimensions in parenthesis Panasonic motor.
- When ordering, always specify the gear reduction ratio along with the indexing drive code number.
- Note:For details on the induction motor, refer to the brochure for Oriental Motors(or Panasonic).
- The overall length of the motor will be less, depending on the reduction ratio.

Timing cam-Photo switch

**(a) Fixed-angle type**

**(b) Variable angle type**

$\alpha^\circ = \text{Max } 180^\circ$

※Up to 2 sets of timing cams and photo switches can be added as necessary.